

GTC 2021

GENERAL TECHNICAL CONDITIONS

EDITION: OCTOBER 2021
Replaces previous version

ADMISSION	4
1 Glass guide	5
1.1 Basic parameters	5
1.2 IGU construction	6
1.3 Basic coatings	6
1.4 Typy szkła	6
2 Packing, storing, cleaning, transporting and assembling	7
2.1 Packing	7
2.2 Storing	7
2.3 Cleaning	7
2.4 Transporting	8
2.5 Assembling	8
3 Standards in the glass industry	9
4 Double glazing	9
4.1 Construction and definitions	9
4.2 Base materials	10
4.3 Glass	10
4.4 Glass cutting	11
4.5 Cutting of shapes	12
4.6 IGU thickness tolerances	13
4.7 Selection of the package thickness for the glass strip	14
4.8 Nominal counting without laminates	14
4.9 Example of calculating a nominal for laminated glass	14
4.10 Rectangular tolerances	15
4.11 Orientation of ornamental glass	16
4.12 PVB film and UV radiation	16
4.13 Glazing glass with reflective glass	17
4.14 Grinding the coating along the edge of the glass	17
4.15 Spacer frames	17
4.16 Inner Georgian bars	18
4.17 Sizing of Georgian bars	19
4.18 Tolerances for the manufacture of Georgian bars	19
4.19 The Colors of Georgian bars	19
4.20 Georgian bars in double-glazing units glasses	19
4.21 Visual assessment of double-glazing units	21
4.22 Assessment conditions	22
4.23 Abbreviation of Quality criteria for window warranty cards	22
4.24 General rules for cleaning glass	24
4.25 Triple glazing units	25
4.26 Insulating-glazing marking	26
5 Thermal treatment of glass	29
5.1 Technological possibilities of thermal treatment processes	30
5.2 Properties of the thermally treated glass	32
5.3 Directional tempering	32
5.4 Tolerances for the convexity of the total glass format	33
5.5 Tolerances for convexity of local glass format	33
5.6 Crack mesh	33
5.7 Visual assessment of tempered glass - single	34
5.8 Marking of heat treated glasses	35
6 Laminated glazing	36

6.1	Definition and construction	36
6.2	Tolerances of external dimensions	37
6.3	Tolerances of mutual movement of formats	37
6.4	Package thickness tolerances	38
6.5	Visual assessment of laminated glass	39
6.6	Production possibilities	40
7	Compatibility of materials	44
8	Selection of glass to be used - Norms	45
9	Polishing the glass Surface - scratches	47
10	Glass corrosion	47
10.1	Removing condensation patterns	49
10.2	Removing labels / cleaning the glass surface	49
11	Butyl flashings	50
11.1	Sealant compatibility	50
11.2	Internal sealant outlet	50
11.3	Chemical butyl flow	50
11.4	Thermal butyl flows	51
12	„Ringing“ of Georgian bars	52
13	Concave and convexity of the glass	52
14	Pressure compensation	55
14.1	Image reflection, convention and convection phenomenon	55
14.2	Distortion in reflection	55
15	Heat soak test - Nickel silfide	58
16	Condensation of water vapor	59
17	Glass cracks	62
17.1	Glass cracks	62
17.2	Crack types	63
18	Optical phenomena	66
19	Thermal analyzes	70
20	Toughening glass with a low-emission coating in the middle position	70
21	Bioclean	71
22	Glass selection	72
23	Window glazing	74
24	VSG laminated glass delamination	74
25	Enameled panes by screen printing	77
25.1	Production possibilities	77
25.2	Description of the technological process	78
25.3	Visual assessment of the print	79
25.4	Color difference tolerances	81
25.5	Standard screen patterns	82
25.6	Non-slip coating - seralit xtragrip	83
25.7	Alarm loop	84
26	Structural glazing	86
26.1	Products used by Glassolutions	86
26.2	Types of structural glazing systems	87
26.3	Sealing with silicone – double glazing	88
26.4	Stepped glass	88
26.5	Quality control of sealants	89
27	Final Provisions	89

ADMISSION

These General Technical Conditions of Saint-Gobain Polska Sp. z o.o. (Glassolutions brand), describe the technical conditions to manufacture of individual products not completely by European standards. They have been prepared based on the manufacturer's knowledge and experience and constitute his intellectual property. The current European standards remain valid and also form the basis of commercial cooperation.

This document specifies selected dimensional tolerances, manufacturing methods, features, physical and mechanical properties, used and appropriate for the manufacture of finished products, such as:

Insulating glass units (IGU): double-glazed units (DGU), triple-glazed units (TGU).
Toughened (ESG) and thermally strengthened (TVG) panes.
Tempered glass with an annealing process (ESG + HST).
Laminated glass (VSG).

Details on the processing of individual types of glass will be discussed in detail in the following chapters, which also contain references to the currently applicable European Standards

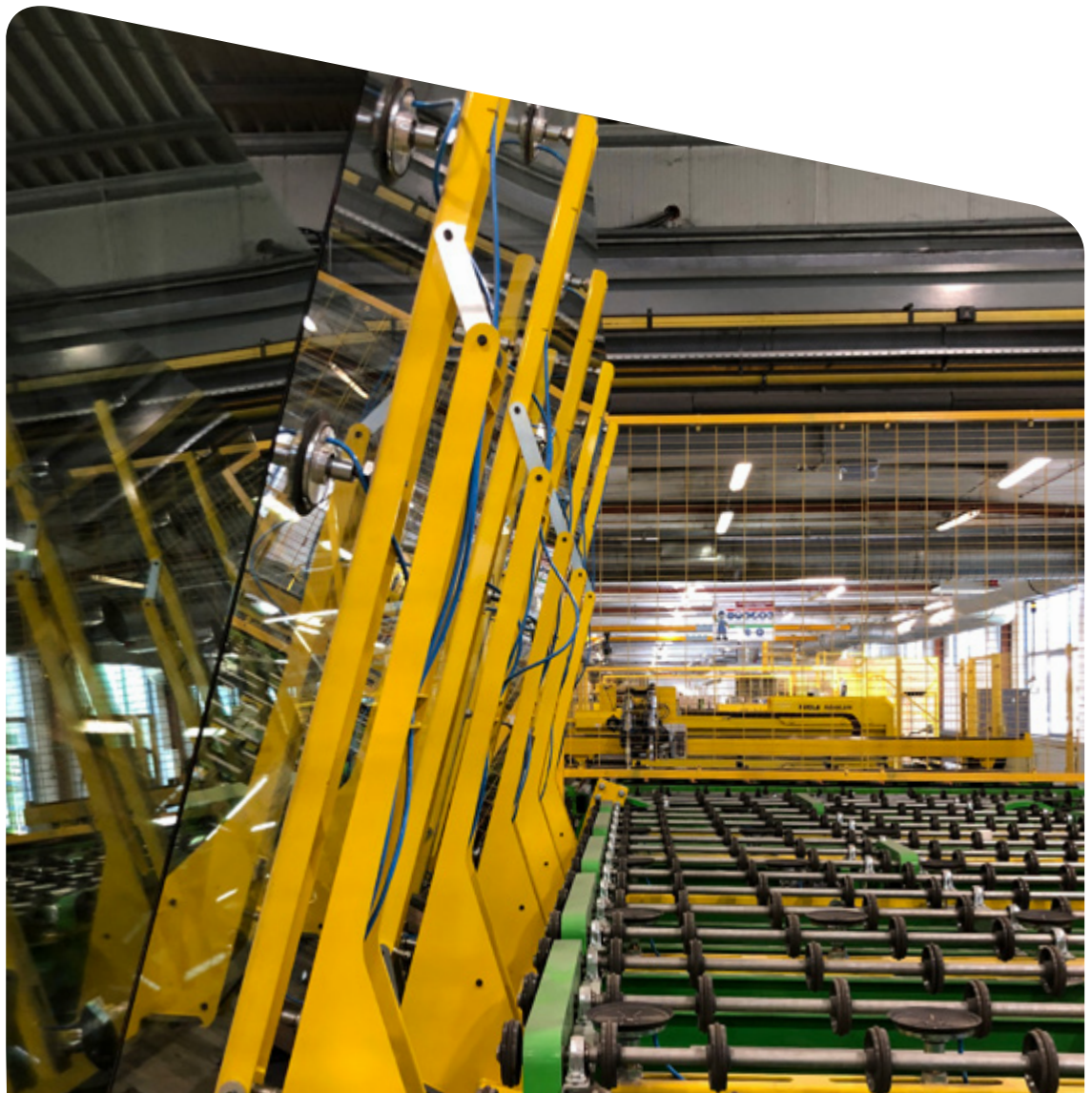

Glass guide

1.1

BASIC PARAMETERS



Lt Light transmission, i.e. how much light the glass allows through. The higher the transmitted light, more there will be in the room



g A parameter that determines the transmission of thermal energy from the sun to the room.



U The heat transfer coefficient, i.e. the value of insulation (the lower the value, the better the thermal insulation of the window joinery).

Fig. 1 Factor U_w of window

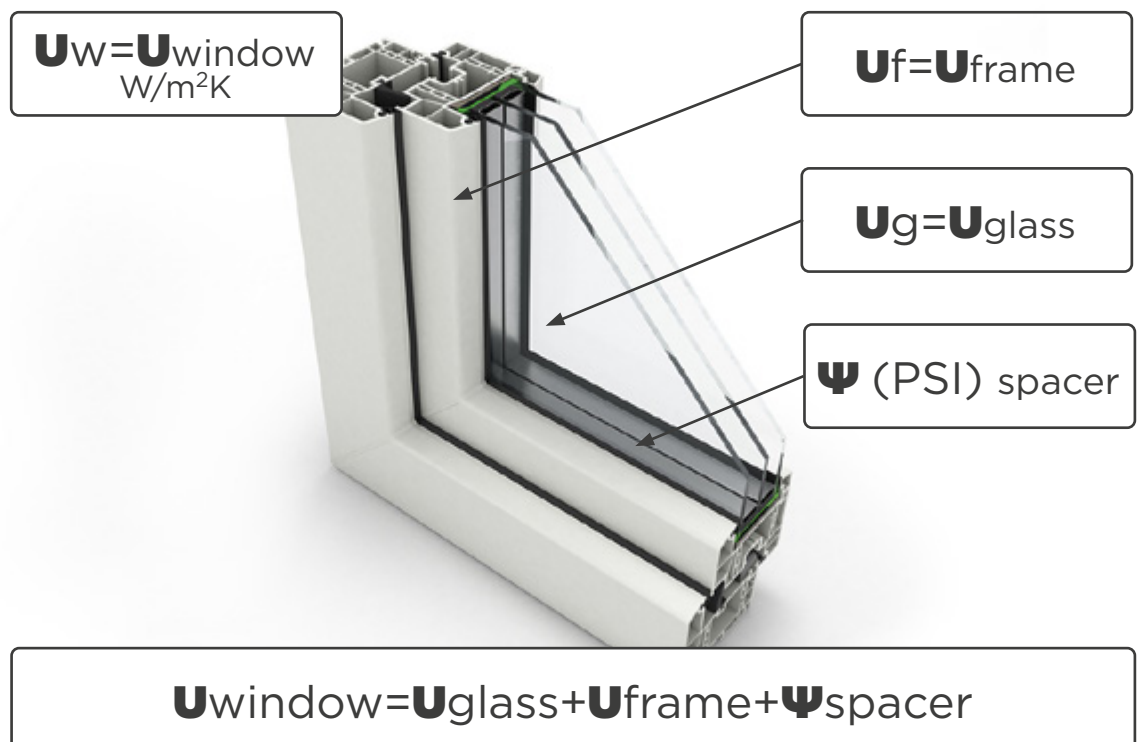

Apart from the glass insulation (U_g) and the window frame (U_f), the total insulation value of the window joinery is also influenced by:

- use of a **Warm Spacer** in a double glazing, e.g. SWISSPACER (min. Reduces phenomenon of steam condensation on the glass surface from the inside rooms”).
- application of **WARM ASSEMBLY**, i.e. als the connection between the window frame and the wall - this is it a critical place when it comes to heat loss and moisture penetration inside home.

1.2

IGU CONSTRUCTION



4,6,8,10 mm – glass thickness (the larger the window, the thicker the glass that must be used).



4/16/4 – standard construction of a double-glazed (single-chamber) insulating glass unit consisting of two 4mm glass panes and a 16mm spacer frame



4/16/4/16/4 – an example structure of a triple glazing (two-chamber) made of three panes of 4mm glass.



Color of the spacer bar - affects only the aesthetic aspects of the combination.

1.3

BASIC COATINGS

XN - Standard Low-E Coating.

ECLAZ - the latest generation of low-emission coatings ensuring extremely high light transmission, recommended especially in rooms on the north side, providing increased access to daylight.

SKN - sun protection coating - a double layer of silver, prevents the „greenhouse effect” in the rooms. Recommended from the south side with large glazing. Please note that air-conditioning rooms is more expensive than heating them.

XTREME - sun protection coating - triple silver layer, one of the best coating available on the market.

1.4

TYPES OF GLASS

FLOAT - Annealed glass, the standard glass for windows

TEMPERED GLASS (SECURIT) - Glass that reduce the risk of serious injuries when broken, e.g. when bumping into a large glass. If broken, it breaks down into small pieces.

LAMINATED GLASS (STADIP)

22.1 - laminated glass consisting of two 2mm glass panes and one PVB foil

33.1 - laminated glass consisting of two panes of 3mm glass and one PVB foil

44.2 - laminated glass consisting of two panes of 4mm glass and two PVB foil

Descriptions of our products are available on the website www.glassolutions.pl/pl/produkty/

2

Packing, storing, cleaning, transporting and assembling glass

2.1 PACKING

IGU (insulating glass units) should be placed on stands. Standard A and L type stands, steel or wooden, with or without a lid, are used for the transport of IGU. The base of the rack with the sides should form a straight angle.

All metal parts of the stand that are in contact with glass should be lined with rubber or other shock-absorbing material. Insulating glass units placed on stands should be secured with tapes against shifting during transport. Cork, cardboard, wooden or other spacers agreed with the customer should be used between the panes. Different packaging should be agreed between the recipient and the supplier.

2.2 STORING

Double glazing should be stored in covered, dry, ventilated rooms, protected against precipitation and direct sunlight, with a temperature not exceeding 40oC. The supplier is not responsible for defects resulting from poor storage.

2.3 CLEANING

General rules for cleaning glass

Glass cleaning, as well as removal of the remains of stickers and spacers, should be carried out by the contractor with the use of mild cleaning agents. Dirt on the glass, which cannot be removed by the usual washing method with plenty of water, a sponge, a rubber band, soft leather or commercial spray cleaners and rags, can be removed with fine industrial steel wool „Rakso 0000” or household cleaning agents.

Sharp tools such as razor blades or scrapers may slightly scratch the surface and should be avoided.

In particular, it is imperative to immediately remove lumps of cement or other remnants of building materials, otherwise it may lead to irreversible damage to the glass surface.

Normal soiling should be removed as described above, abrasives such as scouring agents or a steel sponge should not be used. Difficult to remove dirt, e.g. paint, tar stains or adhesive residues, should be removed with the use of appropriate solvents, such as spirit, acetone or gasoline, and then the glass should be washed with water. It is important to prevent any solvent from contacting the edge seal of the IGU, gaskets or other organic materials (silicone joints) as this may damage them.

Prohibited cleaning agents

Strong alkaline or acid solutions, especially liquid acids and cleaning agents containing fluoride, must not be used. Such solutions can cause irreversible damage to the coatings and / or the glass surface.

Facade and glass cleaning should be performed in accordance with recognized industry standards.

Metal-oxide coated glass

Metal-oxide coated glass requires special measures. Normal soiling should be removed as described above, abrasives such as scouring agents or steel wool must not be used.

Difficult to remove dirt, e.g. paint or tar stains or adhesive residues, must be removed with the use of appropriate solvents, i.e. spirit, acetone or gasoline, and then the glass should be washed with water.

It is important to prevent any solvent from contacting the edge seal of the IGU gaskets or other organic materials (silicone joints) as this may damage them.

Cleaning satin glass

Satin glass has a slightly rougher surface on one side and so side it is possible that this surface will get dirty more easily than a smooth surface and it will be necessary to pay more urgent attention to the maintenance of this type of glass.

For cleaning, silicone-free and acid-free cleaning agents must be used. Strong alkaline solutions as well as acids and cleaning agents containing fluorides must not be used. Cleaning the glass as well as removing residues from stickers and spacers must be done with a mild cleaning agent. Dirt on the glass should be removed using the usual „wet” method, using plenty of water, a sponge, rubber roller, leather or commercially available spray cleaners and rags. Stubborn soiling that cannot be removed with conventional cleaning agents should be initially removed with special cleaning agents (Pril, Ajax, etc.). It is recommended to use the usual „wet” cleaning method afterwards. The use of steam suction cleaners guarantees satisfactory cleaning of heavily soiled areas

2.4

TRANSPORTING

In most cases, transport is carried out by our own specialized trucks, adapted to glass transport. Unloading racks from glass from the truck is carried out by the recipient. The recipient is responsible for correct unloading process and notification of damage found upon delivery.

Own collection takes place at the recipient's request and risk (in terms of breakages and glass damage during the transport).

2.5

ASSEMBLING

The conditions for the assembly of insulating glass units are described in informative Annex C, EN 1279-5 standards, ITB guidelines and other European Standards.

3

Standards in the glass industry

List of Related European Standards:

PN EN 1279-1	„Glass in construction. Insulating glass units. Part 1. General requirements, dimensional tolerances and system description rules.” - Double glazing
PN-EN 12150-1	„Glass in construction. Thermally toughened soda lime silicate safety glass Part 1: Definitions and Description.” - Toughened glass sheets
PN-EN 572-8	„Glass in construction. Basic soda-lime-silicate glass products Delivering products with strict dimensions.” - Float glass sheets
PN-EN 1096-1	„Glass in construction. Coated glass. Part 1: Definitions and classification.” Coated glass sheets
PN-EN ISO 12543-6	„Glass in construction. Laminated glass and laminated safety glass. Appearance.” - Coated glass sheets
PN EN 1863-1	„Glass in construction. Thermally strengthened soda lime silicate glass. Part 1. Definitions and description.” - glass forms made of thermally strengthened glass
PN EN 14179-1	„Glass in construction. Thermally toughened, soaked safety soda lime silicate glass. Part 1. Definition and description.” Toughened and annealed glass sheets

4

Double glazing

4.1

CONSTRUCTION AND DEFINITIONS

Insulating double glazing unit (**IGU**) and triple glazing unit (**TGU**) is a set consisting of two or three glass panes, separated by one or more spacers filled with molecular sieve (desiccant), hermetically sealed along the spacer with a two-stage seal, mechanically stable and durable (see Fig. 2). The standard IGU with Polyurethane or Polysulphide external sealant must be installed in a closed frame system where the edges are not directly exposed to UV radiation or moisture.

- a** Float glass
- b** Gas fill (Argon, Krypton)
- c** Spacer
- d** Internal sealant
- e** Molecular sieve (desiccant)
- f** External sealant

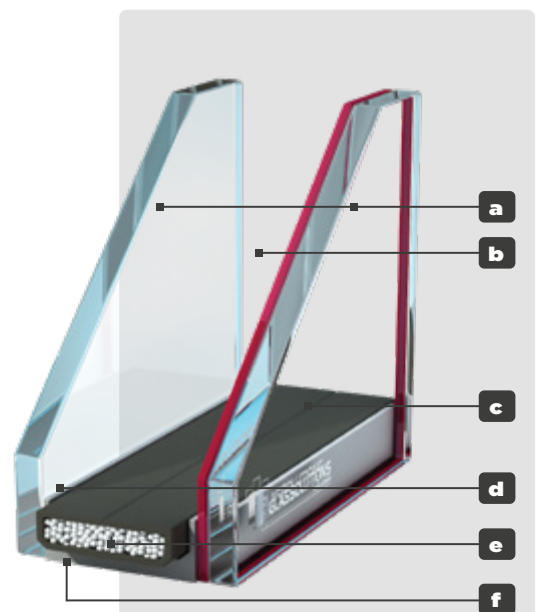

Fig. 2 IGU construction

In order to identify the glass surfaces (s) in the insulating glass unit (e.g. to define the position of the coated surface), the usual numbering is as shown in the figure below:



Fig. 3 Numbering of items in a single-glazed and double glazed unit
Source: own study

4.2 BASE MATERIALS

For the production of insulating glass units, materials and components for which the manufacturer has issued an acceptance certificate / declaration of conformity and a product safety data sheet should be used. If the system is used, these materials should meet the requirements set out in Annex C to PN-EN 1279-1: 2018, PN-EN 1279-1 and PN-EN 1279-4 (2018).

4.3 GLASS

Glass is a very durable material, perfectly elastic, not subject to permanent deformation. However, it is very brittle, meaning that when an increasing bending force is applied, it breaks without any previous symptoms.

The type of glass should be agreed between the producer and the customer. Glass panes should be made of glasses mentioned in point 4.2 of the PN-EN 1279-1: 2018 standard. In the event of using glass that is not covered by the specification, the requirements of materials other than those specified in the description must be met.

The most commonly used types of glass in insulating glass:

- colorless float,
- colored float,
- float with soft and hard coatings, wired glass,
- patterned glass, tempered glass,
- toughened glass with full screen printing and patterns made by screen printing, thermally strengthened glass (so-called semi-toughened),
- thermally heated glass, after the Heat Soak test,
- laminated glass, (glued PVB foil, clear, opaque, colored, laminated glass for special applications (e.g. in foil with increased strength), other types of glass not currently included in European standards (e.g. chemically acid etched, sandblasted, etc.) used in accordance with PN-EN 1279.

4.4

GLASS CUTTING

Glass can be cut manually but is normally cut to size on specialized machines. It is possible to cut monolithic and laminated glass. When specifying glass dimensions for rectangular panes, **the first dimension should be width**, then length (height), dimensions should be given in millimeters.

Table 1 Glass cutting tolerance - float

Thickness of glass [mm]	Glass cutting tolerance - float [mm]		
	B, H ≤ 1500	1500 < B, H ≤ 3000	B, H > 3000
≤ 6	1,0	1,5	2,0
8 - 12	1,5	2,0	2,5
15	2,0	2,5	3,0
19; 25	2,5	3,0	3,5

Table 2 Glass cutting tolerance - wired glass

Thickness of glass [mm]	Glass cutting tolerance - wired glass [mm]		
	B, H ≤ 1500	1500 < B, H ≤ 3000	B, H > 3000
6-10	1,5	2,0	2,5

Table 3 Glass cutting tolerance - ornamental glass

Thickness of glass [mm]	Glass cutting tolerance - ornamental glass [mm]		
	B, H ≤ 1500	1500 < B, H ≤ 3000	B, H > 3000
3-6	1,0	1,5	2,0
8-10	1,5	2,0	2,5

A normal phenomenon during glass cutting is the transverse inclination of the cut edge, which is the deviation of the perpendicularity of the broken edge in relation to the pane surface. The amount of the tilt depends on the thickness of the glass and its characteristics.

Table 4 Tolerance of the transverse inclination of the cut edge

Thickness of glass [mm]	Tolerance of the cut edge [mm]
4, 5, 6	± 1
8, 10	± 2
12	± 3
15	+ 5 / - 3
19	+ 6 / - 3

These tolerances apply to glazing where no edge processing is provided. Larger tolerances are allowed for deburring components.

4.5 CUTTING OF SHAPES

Non - rectangular shapes can be specified and cut. Non-rectangular shapes can be specified by 1:1 templates, DWG files, technical drawing, etc. In all cases the dimensions, orientation of a pattern, coating position, etc. Should be specified in accordance with Fig 3. The templates are stored for a period of 14 days from the date of production. After this time, complaints regarding the dimensions or deviations of the pieces will not be accepted.

In the case of shapes, the dimension tolerance is ± 5 mm

In the absence of information on the order, in the case of non-rectangular glazing, it is assumed that the drawing shows the view of the glass from the inside of the room. In the case of shapes with acute angles, there is a risk of breaking the corner of the model inconsistently with the cutting line. The greater the risk, the smaller the value of the angle.

Therefore, the so-called „Increased risk area” in which the tolerances specified in tables 1, 2, 3 and 4 do not apply. Any imperfections in the shape in this area shall not constitute grounds for a complaint

Fig. 4 Increased risk area X
Source: own study

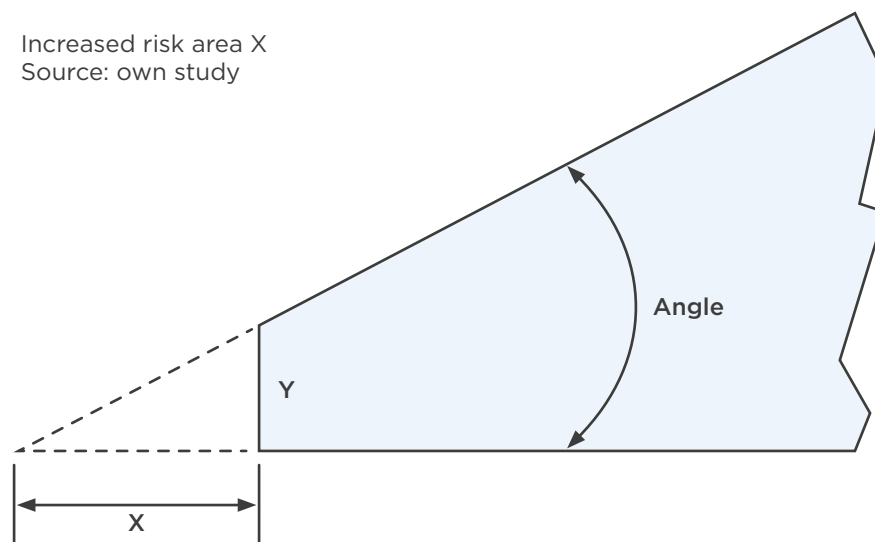

For flat glass, **the minimum Y side length is 25mm**

For insulated glass, **the minimum side length Y 100mm**

In the case of the production of glass on the customer's request, with a side length less than the minimum, the deviations may be greater. - The tightness warranty is maintained, but the quality criteria do not apply. The influence of the model angle on the size of the „increased risk area” is presented in the table below.

Table 5 Area of increased risk of glass cracking

Angle [°]	X [mm]
$\leq 12,5$	30
≤ 20	18
≤ 35	12
≤ 45	8

For glass panes subjected to the toughening or laminating process, the corner should be cut off before heat treatment of the glass, in accordance with the data presented in Table 6 .

Tabela 6 Area to be cut off before tempering and lamination

Angle [°]	X [mm]
≤ 12,5	65
≤ 20	33

For angles > 20° it is not necessary to cut the corners, but there is a possibility of breakage of the glass in the „risk zone” (see Table 5) during heat treatment.

4.6

IGU THICKNESS TOLERANCES

Thickness tolerances for an IGU measured at the sealed edge are shown in Table 7. When measuring the thickness of an IGU reference should be made to the nominal thickness. When laminated glass is used in an IGU assembly consideration should be made for the PVB interlayer, a single PVB interlayer is 0.38mm so the nominal thickness of 33.2 laminated glass would be 6.76mm, for example, however after lamination the PVB is 0.25mm so in practice the thickness would be 6.5mm.

The VSG 33.2 package is composed of 2 panes 3mm thick and two foils 0.38mm thick before laminating, so its nominal thickness is 6.76mm.

The VSG 44.4 package consists of 2 panes, 4 mm thick, and four foils.

Table 7 Thickness tolerances for IGU EN1279-1:2018

IGU type	Thickness tolerances
IGU with 2 glasses (DGU) 2x annealed float	± 1,0 mm
IGU with 2 glasses (DGU) at least one glass tempered or laminated	± 1,5 mm
IGU with 3 glasses (TGU) 3x annealed float	± 1,4 mm (annealed float)
IGU with 3 glasses (TGU) at least one glass tempered or laminated	+ 2,8 mm / -1,4 mm

4.7 SELECTION OF THE PACKAGE THICKNESS FOR THE GLASS STRIP

Recommendation of suppliers of PVC and ALU profiles on how to choose appropriate glazing.

- Profiles-glazing beads are dedicated to the profile and the package, e.g. 40-41, 42-43, 44-45 mm
- The gaskets in the glazing beads additionally have a tolerance of up to 1 mm (for compression) on each gasket, and since the gaskets are on both sides - we have 1-2 mm additionally.
- Having a glazing unit in the nominal of 44 mm with a laminate - it should be assumed that the tolerance of the unit thickness will always be less than the nominal. Assuming that the IGU is in the range 42.5mm to 44mm then a glazing bead in the range of 42-43mm should be chosen and not 44-45mm. In the rare case that the unit >44mm thick then the glazing bead will compensate for this.
- We always select the glazing bead so that the unit is compressed.
- For IG units without laminates, the tolerance can be zero or higher.

4.8 NOMINAL COUNTING WITHOUT LAMINATES

Insulating glass units not incorporating laminated glass.

- Single glass thickness tolerance ± 0.15 mm (narrow SG)
- Frame thickness tolerance up to ± 1 mm depending on the manufacturer, usually ± 0.2 mm
- Thickness of butyl (internal sealant ensuring gas tightness) 0.35-0.5 mm per side.

Table 8 Two types

4/18/4/18/4	Nominal [mm]	Minimum [mm]
thickness of glass	4	3,85
thickness of glass	4	3,85
thickness of glass	4	3,85
thickness of frame	18	17,8
thickness of frame	18	17,8
thickness of inner sealant	0,35	0,35
thickness of inner sealant	0,35	0,35
thickness of inner sealant	0,35	0,35
thickness of inner sealant	0,35	0,35
SUM	49,4	48,55

To sum up for IGU 4/18/4/18/4 the thickness of IGU will always be greater than 48 mm

4.9 EXAMPLE OF CALCULATING A NOMINAL FOR LAMINATED GLASS

Normally glass 44.2 has thickness tolerances of ± 0.4 mm. This is because the PVB film has a gross thickness of 0.38 mm (before the lamination process) and 0.25 mm net thickness already in laminated glass - and this must also be remembered when counting - THIS IS AN INDUSTRY STANDARD.

When counting the nominal value, taking this net correction for the package in 44.2 / 18 / 44.2 - the nominal value is exactly 35 mm - i.e. the glazing bead should be matched to the 34-35 mm package.

Example of real measurement
34,42 mm
34,34 mm
34,27 mm
35,18 mm
35,35 mm
34,92 mm
34,63 mm
34,52 mm
34,31 mm
34,75 mm

Table 9

Measurements show that we are within -0.69 mm/+0.18 mm of the Nominal after net correction for laminated glass.

They are also in line with the tolerances expressed in EN1279.

4.10 RECTANGULAR TOLERANCES

These tolerances apply to the difference in diagonal dimensions for elements with rectangular shapes. The permissible dimensional difference in this case may not exceed 2 mm.

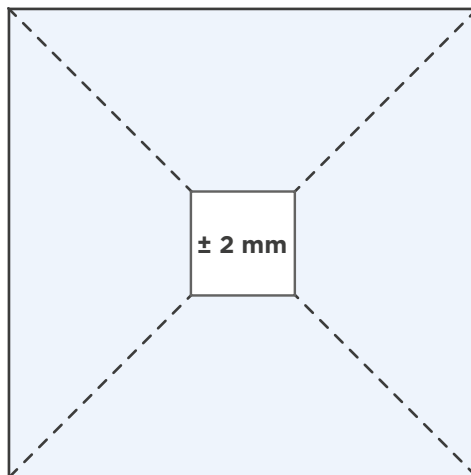

Fig. 5 Permissible tolerance of diagonals
Source: own study

Table 10 Dimension tolerances according to EN1279-1:2018 point 6.3.2

Single or double chamber IGU (insulating glass unit)	Width and height tolerance of IGU	Tolerance of mismatch
All IGU where glass thickness is below 6mm and width and height is smaller than 2000mm	±2	≤2
All IGU where thickness of glass is from 6 to 12mm or the width and height is between 2000 and 3500mm	±3	≤3
IGU where width or height is between 3500 and 5000mm and thickness of glass is below 12mm	4	≤4
IGU where width or height is at least 5000mm or thickness of glass is above 12mm	±5	≤5

For model glass, the dimensional tolerance is ± 5mm

4.11

ORIENTATION OF ORNAMENTAL GLASS

As a standard, the direction of the pattern of the ornamental glass with parallel patterns is made along the vertical edge. A different arrangement of the pattern is allowed only in special cases, when the order is accompanied by a drawing containing information about the direction of the pattern setting. The standard for assembling units with ornamental glass is to have the rough or structured side inside the unit. Although this facilitates the cleaning of the units it also means that the unit does not meet the requirements of EN 1279 and as such these units cannot be guaranteed for gas or water tightness.

The quality criteria for ornamental glazing are described in the standard:

EN 572-5 „Glass in building - Basic soda lime silicate glass products

- Part 5: Patterned glass „and **EN572-6**” Glass in building - Basic soda lime silicate glass products
- Part 6: Patterned wired glass „,

In the case of insulating glass units containing ornamental glass, the guarantee for the tightness of the unit with the „smooth” side to the inside of the unit is maintained. „In insulating glass units with ornamental glass made with CEKAL certificate, the structure / pattern of the ornament is always directed towards the outside of the glazing.”

The combination of the ornament with the structure outside may cause dirt to penetrate into the ornament’s recesses and make it difficult to keep the surface clean. Attempts to remove persistent dirt may damage / scratch the glass. Taking into account the EN1279 standard - such glass panes do not meet its requirements.

The General Terms and Conditions of the Warranty define for insulating glass units a 5-year Tightness WARRANTY (does not apply to insulating glass units with ornamental glass and glass shapes other than those listed in the PN-EN 1279 standard). On the client’s request, we can make glazing units with ornamental glass with the structure (pattern) of the ornament on the outside of the glazing unit. However, this requires additional information entered in the order about setting the structure / pattern of the ornament in the double glazing. Laminating the „rough” side to the PVB foil is not allowed.

4.12

PVB FILM AND UV RADIATION

Laminated glass with PVB foil has a specific ability to absorb UV radiation. Below, the data of the PVB film manufacturer - TROSIFOL®.

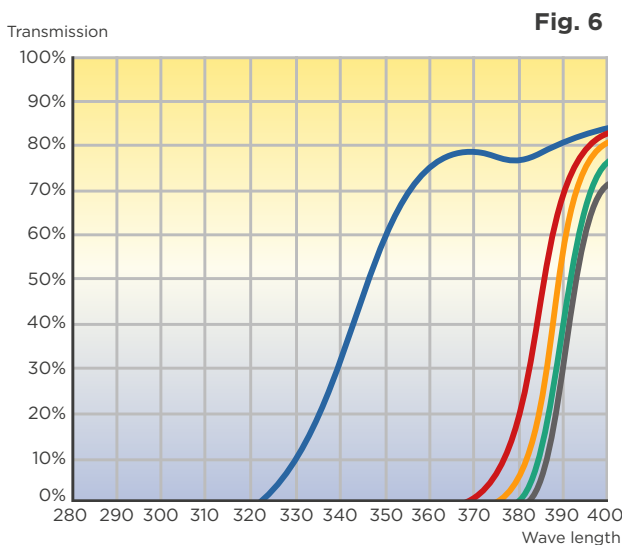

Table 11

Construction	UV-Transmission (measured according to ISO 9050)
2 x 4mm (glass)	43,3%
2 x 4mm (glass) + 0,38 mm TROSIFOL®	≤ 2,4%
2 x 4mm (glass) + 0,76 mm TROSIFOL®	≤ 0,5%
2 x 4mm (glass) + 1,14 mm TROSIFOL®	≤ 0,07%
2 x 4mm (glass) + 1,52 mm TROSIFOL®	≤ 0,02%

UV-Transmission of laminated glass with TROSIFOL MB/PR between 2 sheets of 4mm float glass

4.13 GLAZING GLASS WITH REFLECTIVE GLASS

In the case of using glass with reflective coatings, please specify in the order which position, counting from the outside of the room, the coating is to be placed on (see Fig. 2). In the absence of such information, the panes will be coated in position 2.

4.14 GRINDING THE COATING ALONG THE EDGE OF THE GLASS

In order to ensure the tightness of the unit with off line or “soft” coatings, it is necessary to remove the coating along the edges to be sealed. The width of the ground edge must correspond to the width of the sealant. This solution guarantees the tightness of the package. The edge of the insulating glass is intended to be hidden in the frame, therefore the visual quality of the ground edge is not taken into account and is only intended to ensure tightness of the glazing unit. For glazing with a visible edge for applications other than frame glazing, indicate the type of edge treatment and consider that the soft coating will be ground when ordering this type of glass.

4.15 SPACER FRAMES

In the production of composite packages, a wide range of spacer frames are used, positioned between the glass panes of the unit. Spacers can be aluminum, steel, stainless steel or composite. Different colors are available for certain frame types and frames can also be painted on request. The color of the frame determines the reflection of the edges of the package. Spacer frames can be bent at the corners (joined on the sides in max. 3 places) or cut and joined with special corners. The gap in joined frames cannot be greater than 1 mm. Depending on the technology of filling the inter-pane space of composite packages with technical gas, it is permissible to locate the filling valves in a visible place on the spacer frame.

For the purpose of product identification and traceability, the manufacturer’s standard marking is placed on the spacer frames, including, inter alia, identification of the production plant, order number, construction or dimensions of the glass. Any modifications to the marking on the frame should be agreed with the manufacturer.

The production technology of double-chamber glass consists in the separate production of each chamber, which at the same time means separate positioning of the spacer frame. The tolerance of the position of the spacer frame in relation to the edges of the panes constituting the components of the unit is $\pm 2\text{mm}$.

The tolerance of the execution and overlapping of the distance frames relative to each other, resulting from the IG production system, is 2 mm (see Fig. 7).

Shaping the distance frames for model glass is done manually - the permissible deformation of the frame is greater than in the case of rectangular glass. Possible additional deformations during the shaping of the frames and their overlapping increase the tolerances of the offset frames in relation to each other in this type of triple glazing to $\pm 5\text{ mm}$ in relation to each other (see Fig. 8).

If the customer does not specify the color of the frame in the order, we assume that the standard is always an aluminum frame.

Fig. 7 The tolerance of the frame position in TGU, rectangular glass

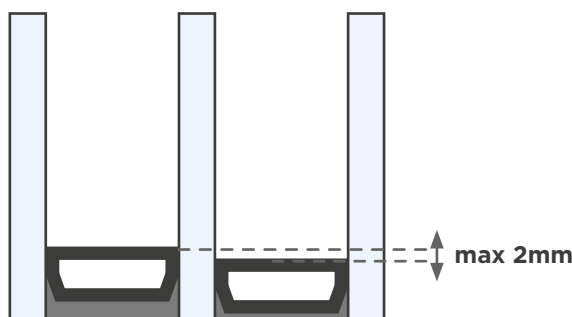
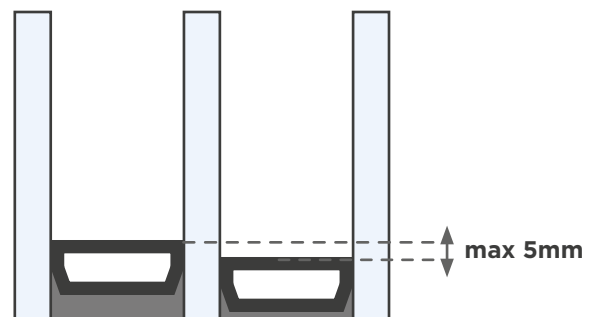

Fig. 8 The tolerance of the frame position in TGU, shape glass (model)



4.16

INNER GEORGIAN BARS

Types of georgian bars

Aluminum Georgian bars are a decorative addition to the IGU and are installed in the cavity between the 2 panes of glass. They are available in widths of 8, 18, 26 and 45mm. The minimum cavity in which Georgian bars can be installed is 12mm and the maximum is 18mm. Georgian bars installed in units with different cavities are manufactured at the sole risk of the customer.

Duplex bars are a different type of Georgian bar and can either be a single piece or 2 spacer bars installed „back to back”. In his case the customer applies an external „Georgian Bar” and the duplex spacer imitates a real georgian style window. This type of bar can be in Aluminium or SWISSPACER® in 20, 24 or 30mm widths

As the glass distorts the color of the Georgian bars it is not possible to use the RAL palette and so Glassolutions have developed their own color palette which will match with the color of the spacer bars that are available. Unless stated in the order the spacer bar color will match the Georgian bar color.

Table 12 Recommended widths of duplex for frame

Frame width[mm]	Duplex width[mm]
12 - 14	9,5
15 - 16	11,5
18 - 20	13,5
22 - 24	17,5

Georgian BAR Connectors

It is possible to connect georgian bars of different widths in the table below.

Table 13 Possibility to connect georgian bars

Horizontal georgian bars	Vertical georgian bars			
	8mm	Helima 18mm	Helima 26mm	Helima 45mm
8 mm	V	-	-	-
Helima 18 mm	-	V	V	-
Helima 26 mm	-	-	V	V
Helima 45 mm	-	-	-	V

Due to different manufacturing technologies & materials slight discolorations may occur at the joints and fixing points of the Georgian bars. Transparent silicone bumpers are glued to the georgian bars, which are designed to:

- Maintain the correct distance between the georgian bars and the glass (at least 2mm per side)
- Limiting the formation of a thermal bridge
- Limit the possibility of the Georgian bars vibrating (ringing effect)

The location of the „bumpons” is determined by a skilled employee based on the dimensions and structure of the Georgian bar assembly. It is also possible to have curved Georgian bars to form arches or to connect them at different angles. The minimum bending radius for 8, 18,& 26mm Georgian & Duplex bars are listed in the tables below.

Table 14 Possibilities of bending Georgian bars - upon individual Customer

Georgian bars width [mm]	Min. radius [mm]
8	100
Helima 18	150
Helima 26	250
Helima 45	no possibility
Duplex alu. 20/9,5	180
Duplex alu. 24/9,5	180
Duplex alu. 30/9,5	180
Duplex Swisspacer	no possibility

There are also Georgian bars from other manufacturers such as ECO-IN / SWS etc.

4.17 SIZING OF GEORGIAN BARS

When ordering IGU with georgian bars, the location of individual georgian bars in the pane should be provided. The dimensions should be given from the edge of the glass to the axis of the georgian bars and between the axes of the georgian bars. When ordering panes with georgian bars, remember about the minimum and maximum dimensions of the georgian bars.

Table 15 Minimum spacing of georgian bars - other than below on individual request

Georgian bars width [mm]	Min. distance from edge of the glass to the axis of the georgian bars [mm]	Min. distance between the axes of the georgian bars [mm]
8	110	60
Helima 18	115	110
Helima 26	120	120
Helima 45	130	140
Duplex 20	115	85
Duplex 24	115	90
Duplex 30	120	95

Table 16 Maximum size of georgian bars fields

Georgian bars width [mm]	Max. size of field [mm]
8	800 x 800
Helima 18	1000 x 700
Helima 26	1000 x 700
Helima 45	1000 x 700
Duplex	1000 x 1000

4.18 TOLERANCES FOR THE MANUFACTURE OF GEORGIAN BARS

During the installation of georgian bars, a maximum deviation of ± 2 mm from the given dimensions may occur. In the case of shapes with arches and according to the template, the deviation from the set dimensions may increase up to 10 mm. When making oblique georgian bars (models and the so-called „Scandinavian” georgian bars), the deviation may amount to ± 5 mm due to the manual production method. With a significant increase in temperature, the georgian bars may slightly bend due to thermal expansion of the aluminum. This effect is almost absent when SWISSPACER® georgian bars are used. If any type of georgian bars is used in two chambers of a double-chamber glazing unit, the dimensional tolerances for the division of georgian bars are ± 4 mm. This is due to the method of producing triple glazing units where they can overlap the deviations of the frame setting, glass folding and the installation of the georgian bars itself. In the case of 8 mm georgian bars, we do not guarantee the straightness of georgian bars (it is acceptable deflection of georgian bars).

4.19 THE COLORS OF GEORGIAN BARS

Georgian bars painted from different manufacturers are installed in insulating glass, therefore different parts of georgian bars may show slight color deviations. It is permissible to correct small paint splashes (caused e.g. during milling), if the corrections are not visible during the visual inspection from a distance of 2 m (in accordance with the visual assessment presented in point 1.12.).

4.20 GEORGIAN BARS IN DOUBLE-GLAZING UNITS GLASSES

In the case of using two-color georgian bars, where one of the colors is white, it is assumed that, provided that it has not been specified otherwise in the order, the white color is installed from the inside of the room. In the case of other color combinations, always specify which color is to be inside the room and which color outside. In double-chamber glazing, the Helima 8, 18, 26 and 45 mm georgian bars is mounted in the outer chamber as standard. When using spacers

of different widths in a two-chamber combination, the georgian bars is mounted on a wider, outer frame. If the georgian bars is to be installed in the chamber from the inside of the room or in both chambers, it must be clearly stated in the order. In double glazing, the Duplex and SWISSPACER® blind georgian bars is installed in two chambers as standard. If the georgian bars is to be installed in only one chamber, it must be absolutely stated in the order. When using spacers of different widths in a two-chamber combination, the georgian bars is mounted on a wider, outer frame.

Under the influence of weather conditions, the georgian bars may sometimes deform from a straight line, they may appear discolored, or they may knock against the glass. Neither of the above cases is classified as a defect. These phenomena intensify with the increase of the dimensions of the glazing unit. When the temperature returns to normal, the bars will return to their original settings. Any visible discoloration of the slats is usually caused by the use of coated glass. The knocking of the slats against the glass (a ringing phenomenon) may be noticeable in certain weather conditions where the IGU is exposed to external vibrations. This means that the georgian bars may vibrate when opening / closing the window. Additional factors are weather conditions, e.g. strong gusts of wind, and the location of the building / building structure / method of installing windows. In the case of a busy street, we will experience vibrations differently. In order to partially reduce the phenomenon of „georgian bars ringing“, the so-called bumpons. The use of the so-called bumpons are designed to protect the glass from damage, not to eliminate vibrations.

Outside

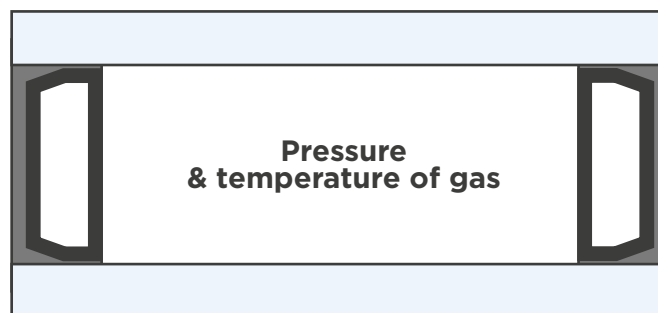

Concavity:

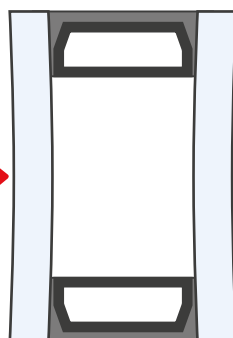

Convexity Bulge:

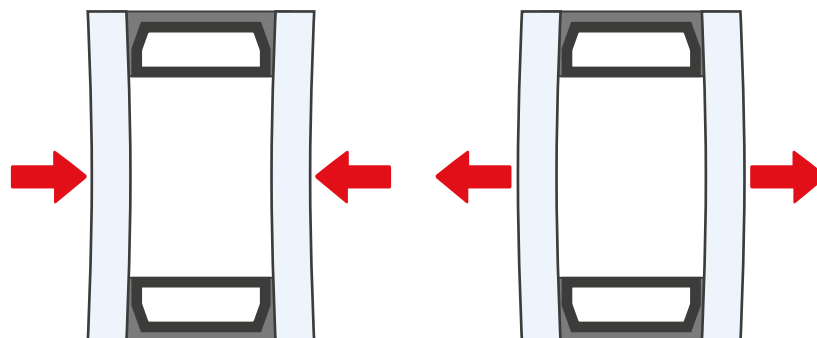
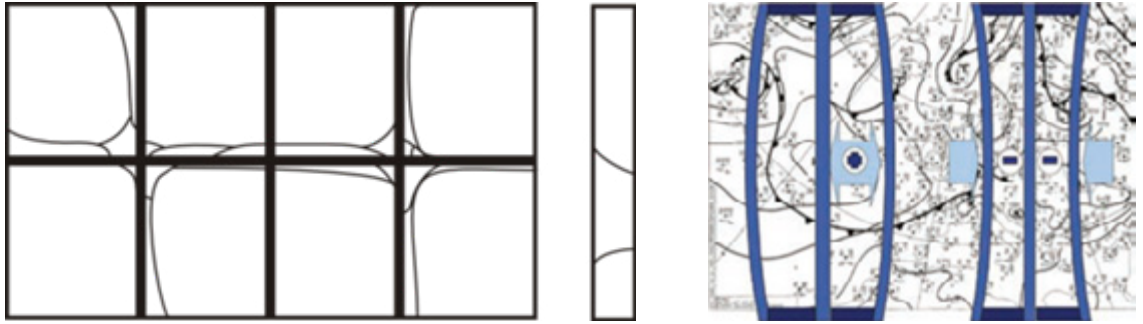

Fig. 9

Fig. 10



None of the above cases is classified as a defect. This phenomenon increases with the size of the glazing unit and the number of georgian bars in the glazing unit.

The slots and georgian bars are installed with a position tolerance of ± 2 mm in relation to the inner edge of the spacer.

In the case of shapes with arches or panes manufactured according to a template, the deviation of the georgian bars from the dimensions may increase up to 10 mm.



„When georgian bars are used in two chambers of a triple glazing unit, the dimensional tolerances for the division of the georgian bars are ± 4 mm.”

„When making oblique georgian bars, the deviation may amount to ± 5 mm due to the hand-made method.”

Due to the uneven temperature distribution for panes, where there is only a georgian bars in one chamber, thermal cracks may appear. We recommend toughening the center pane in this case to minimize the risk of cracking.

4.21

VISUAL ASSESSMENT OF DOUBLE-GLAZING UNITS

Look at Quality Visual Assessment of the Insulating Glass Unit Glassolutions

GLASSOLUTIONS POLSKA is a certified producer of double glazing - meeting the requirements of EN1279.

All components used by Glassolutions, including external and internal sealants, are tested in external bodies, notified for compliance with the EN 1279 standard. The results of these tests cannot be transferred in electronic form, they are only available for inspection at the company's premises.

Any disputes related to the interpretation of the standard should be resolved by a notified body competent for a given standard.

List of Related European Standards:

PN EN 1279-1 „Glass in construction. Insulating glass units. Part 1. General requirements, dimensional tolerances and system description rules. „ - Double glazing

PN-EN 12150-1 „Glass in construction. Thermally toughened soda lime silicate safety glass. Part 1: Definitions and Description. „ - Toughened glass sheets.

PN-EN 572-8 „Glass in construction. Basic soda-lime-silicate glass products. Delivering products with strict dimensions. „ - Float glass sheets

PN-EN 1096-1 „Glass in construction. Coated glass. Part 1: Definitions and classification. „ - Coated glass sheets.

PN-EN ISO 12543-6 „Glass in construction. Laminated glass and laminated safety glass. Appearance.” - Coated glass sheets.

PN EN 1863-1 „Glass in construction. Thermally strengthened soda lime silicate glass. Part 1. Definitions and description. „ - glass forms made of thermally strengthened glass.

PN EN 14179-1 „Glass in construction. Thermally toughened, soaked safety soda lime silicate glass. Part 1. Definition and description. „ Toughened and annealed glass sheets.

4.22 ASSESSMENT CONDITIONS

GLASSOLUTIONS POLSKA is a certified manufacturer of Insulating Glass Units - meeting the current requirements of the EN 1279: 2018 standard (this standard was published in 2018 and from 2020 it is mandatory for all manufacturers.)

We have been applying the provisions of this standard since February 2019 and they are included in our Quality Criteria. In the case of glass manufactured before February 2019 - the older Quality Criteria apply accordingly. Any disputes related to the interpretation of the standard should be resolved by a notified body competent for a given standard.

Glassolutions products do not have the historically used B Mark, therefore the Technical Criteria No. 20 / s do not apply. In the light of legal liability and European standards - the insulating glass units were made according to Standards EN 1279 and should be assessed according to this standard.

The European Standard (EN 1279) is the overriding standard, which presents the obligatory requirements, as well as refers to the criteria according to which insulating glass units should be visually inspected; European Harmonized Standards (hEN) with the EN1270 standard, such as hEN 572 - float glass / hEN 1096 - coated glass / hEN 12150 - toughened glass and hEN 12543/14449 laminated safety glass - the given criteria contain for phenomena and defects that are not included in standard EN1279

If your opinion is different from ours, it is possible to appeal to the Institute of Ceramics and Building Materials, which is a Notified and deciding body. The binding document for Glassolutions products are the Quality Criteria for Insulating Glass Units available at www.glassolutions.pl/pl/gwarancja-ce

Additionally, at the client's request, we can prepare a separate letter explaining in detail the assessment principles, applied tolerances and basic standards for final clients (investors). The letter can serve as a supporting argument for investor acceptance along with the European norms.



4.23 ABBREVIATION OF QUALITY CRITERIA FOR WINDOW WARRANTY CARDS

It is important that the above quality criteria for insulating glass reach end customers, below is a summary of the criteria.

Standard for assessing the quality of glass

1. The glass panes used in the production of PVC / wooden / aluminum joinery are manufactured in accordance with the quality and process requirements contained in the European Standard EN 1279: 2018. It should be noted that the natural properties of glass combined with the different manufacturing process required to meet the desired final functional parameters can occasionally affect the appearance of the installed product
2. Perform a visual inspection in accordance with EN1279: 2018 (Glassolutions Quality Criteria, February 2019 edition)

3. Look at the glass in a vertical plane at a straight angle (90 °) to the glass surface from inside the room. Stand 2 m from the inspected glass. Carry out the inspection in natural daylight under evenly overcast skies, but not in direct sunlight. The glass must be completely dry. Defects cannot be marked on the glass

Fig. 11

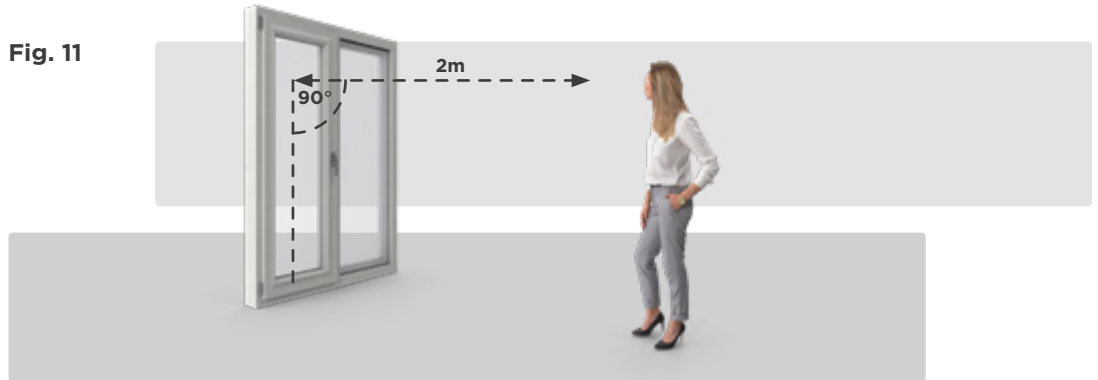

4. You must look through the glass and not at the glass when performing the visual inspection. If the defect is not visible when looking through the glass at a certain distance, then it is considered that such defect does not disturb the image and does not affect the product properties, i.e. translucency, thermal and acoustic insulation.
5. Not every visible defect qualifies the glass for replacement. We look through the glass, not at the glass.
6. When inspecting the glass, do not use magnifying devices or strong light sources (e.g. halogen lamps and flashlights). The assessment should not be carried out when the glass pane is exposed to strong sunlight.
7. Due to the fact that insulating glass units consist of more than one glass pane, the viewer may notice multiple reflections. This effect will be stronger in triple glazing. It is not a defect of the glass.
8. The hermetically sealed space between the panes contains a fixed volume of air / gas, dictated by the temperature and atmospheric pressure values prevailing at the time of joining. After the installation of the glass, changes in the outside temperature and pressure will result in an increase or decrease in the volume of air / gas in the space between the glass panes, which in turn will cause the glass pane to bend visible in the form of a distorted reflection image. This distortion indicates that the glazing has been properly sealed and is not a sign of a glass defect. The phenomenon is described in the EN1279-1: G.5 standard
9. Toughened glass may show some visual and color distortions, more emphasized in the reflection of images from double glazing units. Such surface colors and patterns do not indicate a change in the physical properties of the pane and are not indicative of a defect.
10. Hairline scratches (width ≤ 0.2 mm) normally invisible under visual inspection from 2 meters are acceptable if not present in clusters, with:
 - the cluster is more than 3 defects in a circle with a diameter of 20 cm;
 - scratches and line defects with a thickness of 0.2 mm to 1 mm are subject to assessment;
 - scratches with a thickness greater than 1 mm are assessed as point defects;
 - main area - a single scratch / line defect is allowed max. up to 15 mm; the total length of line scratches / defects is max. up to 45 mm;
 - edge area - a single scratch / line defect is allowed max. up to 30 mm; the total length of line scratches / defects is max. up to 90 mm.
11. Defects smaller than 0.5 mm are not taken into account during the Visual Assessment of the Insulating Glass Unit.
12. Point defects and blisters in the glass are unacceptable if their size exceeds 2 mm (stains, stains and dirt are 3 mm)
13. Water condensation on the glass surface from the room side is caused by the presence of warm, humid air closed in the building. This indicates a problem in the structure of the building itself and the need to ensure better air ventilation - water condensed on the glass surface is in this case a symptom, and not a defect of the glass.
14. The condensation of water outside. The presence of condensed water on the outer surface of the glass is a positive indicator of the thermal insulation of the glass. It is not a defect of the glazing unit.
15. Georgian bars Under the influence of weather conditions, georgian bars can sometimes deform from a straight line, they may appear discolored, or they may knock against the glass. Neither of the above cases is classified as a defect. These phenomena intensify with the increase of the dimensions of the glazing unit. When the temperature returns to normal,

the bars will return to their original settings. Any visible discoloration of the slats is usually caused by the coated glass. The knocking of the strips against the glass may be noticeable under certain conditions, during which the insulating glass unit is exposed to external vibrations, e.g. in strong gusts of wind. The use of the so-called bumpons are designed to protect the glass from damage, not to eliminate vibrations. The slots and georgian bars are installed with a position tolerance of ± 2 mm in relation to the inner edge of the spacer.

16. Thermal cracks. Cracks due to thermal stress appear when the glass temperature changes suddenly. The risk of thermal cracks increases in installations with high partial shading, where glass is the support element (e.g. posters, furniture), where curtains, blinds, films are used, and where heaters or air conditioners are directed at the glass. Such cases are not covered by the warranty.
17. Detailed standards for assessing the quality of insulating glass units can be found at: www.glassolutions.pl/pl/gwarancja-ce

4.24

GENERAL RULES FOR CLEANING GLASS

Glass cleaning, as well as removal of the remains of stickers and spacers, should be performed by the contractor with the use of mild cleaning agents. Dirt on the glass, which cannot be removed by the usual washing method, with plenty of water, a sponge, rubber band, soft leather or commercially available spray-on cleaners and rags, can be removed with fine industrial steel wool or household cleaners.

Sharp tools such as razor blades or scrapers may slightly scratch the surface and should therefore be avoided. It is especially necessary to immediately remove lumps of cement or other remnants of building materials, otherwise it may lead to irreversible damage to the glass surface. If sealant remains on the glass during sealing work, remove them immediately.

Normal soiling should be removed as described above, while abrasives such as scouring agents or a steel sponge should not be used. Difficult to remove dirt, e.g. paint or tar stains or adhesive residues, should be removed with the use of appropriate solvents, such as spirit, acetone or gasoline, and then the glass should be washed with water. It is important to prevent any solvent from contacting the edge seal of the glass packet, gaskets or other organic materials (silicone joints) as this may damage them.

Cleaning agents not recommended

Strong alkaline or acid solutions, especially liquid acids and cleaning agents containing fluoride, must not be used. Such solutions can cause irreversible damage to the coatings and / or the glass surface.

Facade and glass cleaning should be performed in accordance with recognized industry standards.

Glass covered with a metal oxide coating

Glass coated with a metal oxide coating requires special measures. Normal soiling should be removed as described above, however, abrasive agents such as scouring agents or steel wool should not be used.

Difficult to remove dirt, e.g. paint or tar stains or glue residues, should be removed with the use of appropriate solvents, e.g. spirit, acetone or gasoline, and then the glass should be washed with water. It is important to prevent any solvent from contacting the edge seal of the glass packet, gaskets or other organic materials (silicone joints) as this may damage them.

Cleaning satin glass

Satin glass has an etched surface (rough side). Such a surface is susceptible to dirt. Particular attention should be paid to the maintenance of this type of glass.

When cleaning the glass, do not use cleaning agents containing silicones, acids and fluorides. Additionally, strong alkaline solutions should not be used. Cleaning the glass as well as removing residues from stickers and spacers must be done with a mild cleaning agent.

Dirt on glass should be removed using the usual „wet” method, using plenty of water, a sponge, rubber roller, leather or commercially available spray cleaners and rags. Stubborn soiling that

cannot be removed with conventional cleaning agents should be initially removed with special cleaning agents (Pril, Ajax, etc.). It is recommended to use the usual „wet” cleaning method afterwards. The use of steam suction cleaners guarantees satisfactory cleaning of heavily soiled areas.

Stubborn dirt should be removed with appropriate cleaning solutions, but do not use fine steel wool or sharp edges such as razor blades or scrapers. Cleaning solutions containing abrasive particles are not recommended.

To remove tough stains such as paint or tar, or adhesive residues, use appropriate solvents, e.g. spirit, acetone or gasoline, and then dirty surfaces should be washed with water. It is important to prevent any solvent from contacting the pack edge seal, gaskets or other organic materials (silicone joints) as this may damage them. During the finishing works (e.g. plastering), residues can be splashed onto the glass, these residues should be removed immediately with a sponge and plenty of water. The materials used for plastering contain lime which damages the glass surface.

There are many possible types of glass staining. It is not possible to develop instructions on how to counteract each of them. In particularly heavily soiled areas, we suggest performing tests on parts of the surface that will not be visible. The information contained in this manual is based on many years of experience, but is not exhaustive. Follow the instructions for the individual cleaning agents.

4.25

TRIPLE GLAZING UNITS

The EN1279 standard (insulating glass units) does not provide for the production of three-chamber glass. In order to meet the expectations of the market and customers, a specification for this type of combinations has been developed. The document below is an appendix contained in the General Terms and Conditions of Sale and the General Warranty Conditions.

Specification for 3-chamber / 4-shaft glazing:

- The permissible number of all defects specified in the Quality Criteria increases by 1 pc.
- Unit thickness tolerance + 3 / - 2 mm
- Max. Shift of frames ± 2 mm between frames with adjacent chambers
- The georgian bars offset max ± 2 mm between the georgian bars with adjacent chambers
- When the georgian bars are used in 3 chambers, the dimensional tolerances of the georgian bars division are ± 5 mm; when making inclined georgian bars, the deviation may amount to ± 6 mm due to the hand-made method
- Max. Shift of the glass ± 4 mm between the maximally extended glass forms
- For models: The offset of the frames max. ± 5 mm between the frames, the offset of the georgian bars max. ± 10 mm between the georgian bars.
- Gassing at the level of min. 75%

All components of the glass must be hardened and edges seamed - in the case of three-chamber glass, there is a very high probability of thermal cracks. If it is necessary to use laminated glass, a written consent from Glassolutions is required. In special cases, it is possible to use laminated glass as an external component. Laminated glass must be edges seamed.

- Internal components must remain hardened.
- Necessity to use a warm frame
- Max ratio of sides 1: 6
- On straight sections, the external sealant may protrude beyond the contour of the glass in some places.
- Due to the heavy weight of the 3-chamber glass pane, the maximum size that can be produced is each time confirmed in writing by Glassolutions.
- The maximum thickness of the joint is 80mm
- When ordering 3-chamber glass - the customer accepts the above specification.

In case of any questions, we remain at your disposal.

4.26 INSULATING-GLAZING MARKING

According to REGULATION (EU) No 305/2011 OF THE EUROPEAN PARLIAMENT AND OF THE COUNCIL of 9 March 2011 / CE Marking rules on the EEA / ASTM E2188 / 2189/2190 & 2649 (which are the US standard for insulating glass units) introduced and in force marking of insulating glass, allowing for the tracking of the product during its life, as well as during the valid warranty period:

FRAME DESCRIPTION

1. Plant identification (obligatory), eg GL PRU
2. Date and Time of Production (optional)
3. Product name and structure (optional)
4. Order number Order / Item (mandatory)
5. Other information (optional)
6. Dimensions (option)

Print on spacer:

GL.BAR 15/01/2019 0555 X 0383 Glassolutions 2050756/9 SGG Climatop 21098/3 - A BYKLE VINDU



Due to the production technology of frames and insulating glass units / the position of the frame marking in relation to the insulating glass and, consequently, the entire window (left / right / top / bottom) is optional - and it is not subject to a complaint or warranty.

Any deviation from the description in the frame (mandatory information) requires the customer to submit a written request.

If a customer does not want the mandatory inscription or a different inscription on the frame then it could result in a lack of traceability and if there are no markings the unit is not covered by the warranty.

Additional information provided by Glassolutions:

- Trade name of the product (obligatory)
- Glass construction (on customer's request)
- Glass dimensions (mandatory)
- Order number and item (mandatory)
- Bar code (mandatory)
- Customer name (option)
- Customer reference number (optional)

IDENTIFICATION

In accordance with the guidelines of the European Union and CE marking - there is no obligation to place the full structure of the product on the label, often the first lines of the ORDER CONFIRMATION or the INVOICE for the product are printed.

The traceability of the product is ensured by printing the order number and position on the label.

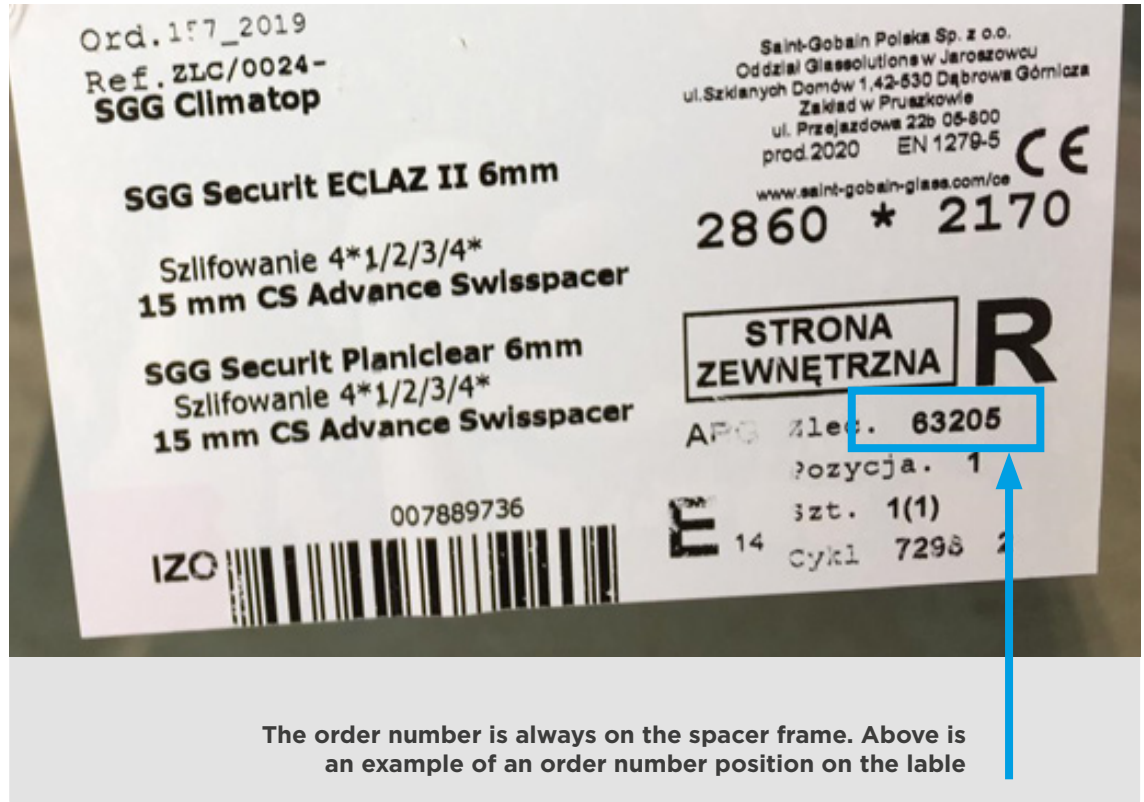

GLASSOLUTIONS SAINT-GOBAIN

POTWIERDZENIE ZLECENIA

Nr zlecenia: **304675**
ZAMÓWIENIE NR 1

strona: 1

Dostawca: Saint-Gobain Polska Sp. z o.o.
Oddział Glassolutions w Jaroszewcu
ul. Szklanych Domów 1, 42-530 Dąbrowa G.
Zakład w Jaroszewcu, ul. Kolejowa 1
32-312 Jaroszewiec
tel. +48 32 6499 520
fax +48 32 6499 518
Numer rejestrowy BDO – 000002847

Nr klienta: 990003
JAN KOWALSKI
KOLEJOWA 1
32-312 JAROSZOWIEC

Dzień wysyłki: 07.04.2021
Dostawa: 07.04.2021

Rejestracja: Dawid Nowak

\$OSP1

Poz.	Nr art.	Ilość	Szerokość	Wysokość	OMS	mb/poz	m2/poz
	SGG Climaplus	SGG Planiclear 4mm	SGG Planitherm XII 4mm				
	16 mm Aluminium						
	*** Wypełnienie gazowe ***						
001	31121301	1	350 x	500	16		
	SGG Climaplus 350 x 500 304675/1 JAN KOWALSKI						

Ref: REFERENCJA KLIENTA
1,70 0,16

On the left is an example of an order confirmation document. The document contains information: complete construction, additional requirements, allowing for the identification of the glass, order number and position

Thermal treatment of glass

In order to increase the strength of the glass, it is possible to use heat treatment.

**Toughened
(Tempering)
(ESG)**

**Heat strengthening
(TVG)**

**Heat soaking
(HST)
Heat Soak Test**

Heat treatment in the form of toughening and heat strengthening of glass is performed in accordance with PN-EN 12150 and PN-EN 1863. It consists in increasing the strength of glass by transferring loads and temperature changes.

Heat treatment in the form of an additional HST (Heat Soak Test) test is carried out optionally on the toughened glass ESG in order to reduce the phenomenon of spontaneous breakage of the toughened glass caused by nickel sulphide inclusions in the internal structure of the material. This processing is performed in accordance with the PN-EN 14179 standard.

The nature of the toughening process makes it impossible to obtain a product as flat as annealed glass. The differences depend on the nominal thickness, dimensions and ratio between dimensions.

Therefore, deformation in the form of overall relief and local relief and other phenomena causing optical distortion of the heat-treated glass can occur. The exact method of measuring the overall bow is described in the relevant standards.

ESG

Toughened glass is characterized by increased mechanical and thermal strength and a special way of breaking when broken into small, usually blunt fragments, which is why it is considered safe. The process of traditional ESG toughening according to EN12150 is carried out in horizontal oscillating furnaces. The glass is heated close to its softening point until it reaches the appropriate temperature and viscosity. After heating, a stream of air is directed onto the glass to cool the glass quickly.

The increased mechanical and thermal strength of toughened glass is explained as a result of a specific distribution of thermal stresses. In the cross-section of the glass, with symmetrical, homogeneous cooling, such a system of stresses is obtained, where the outer layers are the compressive stress zone, and the inner layers are the tensile stress zone. The compressive stresses in the surface layers of the glass allow the application of a much greater bending load than in the case of normally annealed glass by compensating tensile stresses and thus reduce the resultant local stress. The average breaking stress for toughened glass exceeds the strength of ordinary glass several times. The phenomenon of static glass fatigue is also reduced.

TVG

Semi-toughened glass (TVG) according to EN 1863 is obtained by thermal treatment. Its purpose is to increase the mechanical and thermal resistance of the glass. The differences between toughening and semi-toughening are primarily the different fracture pattern and the lower strength of TVG glass compared to ESG. It is worth remembering that semi-toughening glass is not safety glass. If broken, the thermally strengthened soda-lime-silicate glass will break in a manner similar to that in which annealed glass breaks.

HST

The Heat Soak Test method according to EN 14179-1 is a verification test for glass in which nickel sulphide (NiS) may have precipitated. The method itself consists in heating the toughened glass to a temperature of about 290°C and keeping it there for the time specified in the standard. During this time, with a probability close to 99%, the glass panes with inclusions are exposed and they break.

The presence of very small particles of nickel sulphide (NiS) is associated with the possibility of their occasional getting into the glass mass during the float glass production process. Then, during processing, under the influence of heating the glass in the tempering process, the nickel

sulphide particle contained in the glass pane changes its volume (undergoes a polymorphic transformation). Sudden cooling after heating the glass, which causes it to harden, makes the nickel sulphide particle, which takes a certain amount of time to return to its original volume, impossible (it remains in a meta-permanent state). It gets „frozen” in their condition, which in the future may create additional stresses in the glass pane. This mechanism works like a delay bomb.

In the mounted, tempered glass sheet with the inclusion of nickel sulphide particles, which is heated, e.g. under the influence of solar radiation, the volume of the particle slowly increases, which causes additional increase in internal stress. If such a particle is placed in the tensile stress zone, there is a very high probability that the allowable stress level will be exceeded and that the glass pane will break spontaneously. The table below summarizes the possibilities of the HST line. It is worth emphasizing that during the annealing process, the safety class and strength parameters do not deteriorate. The advantage of performing the HST test is obtaining a very high probability that the installed glass will not break spontaneously due to the presence of NiS. A glass damaged due to the presence of nickel sulphide is shown in Figure 30. The test can be performed with soft-coated and figured glass.

In order for the glass to be toughened, minimal edge treatment is required:

1. edge deburring for glass with a thickness of up to 8 mm inclusive,
2. edge grinding for glass ≥ 10 mm thick.

Such requirements are justified because during the tempering process, the glass experiences significant stresses which concentrate on the edges of the glass. An improperly prepared edge may cause the pane to break.

As with all edge machining processes, holes, cutouts and milling must be performed prior to hardening. It should also be remembered that the presence of holes and cutouts increases the risk of glass breakage during the toughening process.

5.1 TECHNOLOGICAL POSSIBILITIES OF THERMAL TREATMENT PROCESSES

Table 17 Toughened process (tempering ESG) - possibilities.

TEMPERING FURNACE		
mm	Standard	Complex
Glass thickness mm	4-12	15, 19
Min. size	200x300	50x50
Max. size	2800x5000	2850x5000
Max. weight	400	440

Table 18 Dimensions of ESG toughened glass

ESG				ESG			
Soft coatings				Float/colors/hard coatings			
mm	Glass thickness	Standard	Complex	mm	Glass thickness	Standard	Complex
Max. size	4	1600x2600	Kontakt DT	Max. size	4	1800x2600	Contact
	6	2500x4000	Kontakt DT		5	2100x3500	Contact
	8, 10	2850x5000	Kontakt DT		8,10,12	2850x5000	Contact
Min. size	4-12	200x300	50x50		15	2850x4200	Contact
	4-12	440	440		19	2850x53300	Contact
Max. weight	4-12	440	440	Min. size	4-12	200x300	50x50
				Max. weight	4-19	400	440

Table 19 Dimensions of TVG semi-toughened glass

TVG				TVG			
Soft coatings				Float/colors/hard coatings			
mm	Glass thickness	Standard	Complex	mm	Glass thickness	Standard	Complex
Max. size	4	1600x2600	Kontakt DT	Max. size	4	1800x2600	Contact
	6	2500x4000	Kontakt DT		5	2100x3500	Contact
	8,10	2850x5000	Kontakt DT		8,10,12	2850x5000	Contact
Min. size	4-12	200x300	50x50	Min. size	4-12	200x300	50x50
Max. weight	4-12	440	440	Max. weight	4-12	400	440

Table 20 Other coating

Other coatings	
Glass type	Tempering
STB 120 STB 136 STOPSOL ANTELIO	Yes
ST 108 ST 120 ST 136 ST 150	Yes
BIOCLEAR ST 150 BIOCLEAR SOLAR CONTROL II	Yes
LACOBEL T PLANIBEL G SUNERGY	Yes
PLANISTAR BIOCLEAR PLANISTAR	No
LUSTRA LACOBEL OmiDecor	no

Table 21 Pattern glass

Pattern glass	
Glass type	Tempering
101 ARENA C CHINCHILLA DELTA FLUTES KATHEDRAL	Yes
MASTER: CARRE LENS LIGNE POINT SHINE	Yes
KURA LISTRAL L, M MONUMENTAL NEMO NIAGARA	Yes
RIPPLE SATINOVO SILVIT VISION SUN WATERDROP	Yes

Pattern glasses reinforced with a steel mesh cannot be tempered.

Table 22 HST production possibilities

HST		
mm	Standard	Complex
Glass thickness	4-15	19
Min. size	100x300	below
Max. size	2425x4400	2800x4450
Max. weight	300	400

HST can be made for all types of ESG glass. At the customer's request, also on TVG glass. Pattern glasses reinforced with a steel mesh cannot be tempered.

5.2

PROPERTIES OF THE THERMALLY TREATED GLASS

During the toughening process, the hot glass comes into contact with the rollers of the furnace, resulting in surface deformation deteriorating its flatness, known as „roller waviness”. The waviness of the rollers is usually visible in the image of the surroundings reflected on the glass. Marks of small impressions („rebouncing of rollers”) may also appear on the surface of glass, which is more than 8mm thick.

This phenomenon is related to the technological process and it cannot be eliminated in the heat treatment process, which is thermal hardening and thermal annealing. It should be remembered that additional phenomena resulting from thermal treatment may occur in toughened glass. These phenomena do not mean that the toughened glass is defective. We include among them:

The phenomenon of rainbow formation - caused by the anisotropy of strength and the formation of a specific stress field created during hardening (Fig. 24). It causes a double refraction of light in the glass, which becomes visible in polarized light - stress fields are visible in the form of colored areas called „polarizing poles” or „leopard spots”. The „polarizing fields” are visible on the glass viewed at a slight angle also in daylight (this phenomenon is clearly visible on toughened car windows).

„Roller Wave” - formed during glass toughening in horizontal furnaces - these are surface distortions caused by the contact of a hot glass (temperature close to the softening point) with the furnace rollers. Then deviations of the straightness of the glass arise. These distortions are usually visible in reflected light. When placing orders for glazing for glazing facades of buildings, it is recommended that the client considers „Roller Wave” phenomenon and determine the direction of applying the glass to the toughening furnace (directional toughening).

„Reflection of rollers - with glass whose thickness exceeds 8 mm and with thinner but larger glass, signs of small impressions may appear („reflection of rollers”).

5.3

DIRECTIONAL TEMPERING

Directional toughening considers the phenomenon of „waviness” of the glass from the rollers of the toughening furnace.

It is a technological procedure aimed at improving the visual and aesthetic aspects and the harmony of the glazing over the entire glazing surface or the building facade by obtaining one direction of reflection of the rollers.

The figures below show the directional quenching in relation to the height H (furnace rolls perpendicular to the dimension H) and the directional quenching in relation to the width B (the furnace rolls perpendicular to the dimension B).

Fig. 12 Directional toughening relative H

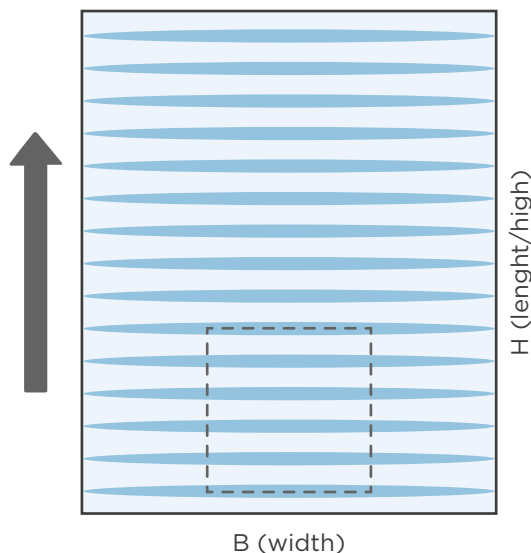
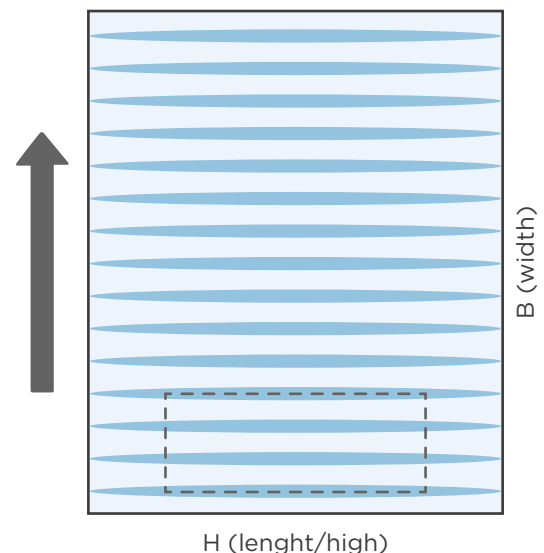

Fig. 13 Directional toughening relative B



Directional toughening of the glass is not possible if its B or H dimension (depending on the toughening direction) exceeds the width of the toughening furnace.

In this case, the glass will be tempered depending on the production capabilities without additional arrangements with the customer.

In the event of the need for directional toughening of glass panes, such a case should be reported when placing the order with the indication of the toughening direction. Otherwise, the glass will be toughened without taking the directionality into account.

5.4 TOLERANCES FOR THE CONVEXITY OF THE TOTAL GLASS FORMAT

The total convexity for float glass in accordance with PN-EN 572 should not exceed 3 mm per 1 meter of product width / length, and for other types of glass 4 mm per 1 meter of product width/length.

5.5 TOLERANCES FOR CONVEXITY OF LOCAL GLASS FORMAT

The local convexity is usually relatively close to the periphery of the glass.

The local convexity for toughened glass (ESG) and for toughened glass with the Heat Soak test should not exceed 0.5 mm by 300 mm.

The local convexity for thermally strengthened glass (TVG) in the case of base glass made of float glass in accordance with PN-EN 572 should not exceed 0.3 mm by 300 mm, and for other types of glass 0.5 mm by 300 mm.

Table 23 Tolerances of convexity toughened glass

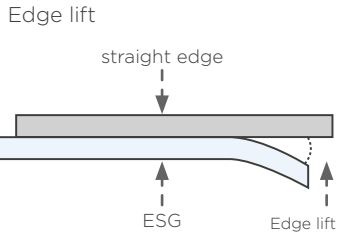
 <p>Convexity (overall)</p> <p>Roller wave</p>	Glass type	Overall ball (mm/m)	Max. convexity (local overall bow) (mm)
	Without coating	3	0,3
	Other glass	4	0,5
 <p>Edge lift</p> <p>straight edge</p> <p>ESG</p> <p>Edge lift</p>	Glass type	Nominal thickness (mm)	Max. edge lift (mm)
	Without coating	3	0,5
		4, 5	0,4
		6,8,10,12,15,19,25	0,3
Other glass	all	0,5	

5.6 CRACK MESH

The heat treatment process of glass changes its fracture mesh structure in the event of breakage. Toughened and toughened glass with an additional HST annealing test breaks into numerous small pieces when broken. The edges of the fragments are mostly blunt, hence this type of glass is considered safe.

When broken, heat strengthened glass breaks in a manner like that of annealed glass. The glass cracking pattern test is destructive, therefore it is performed on standardized samples produced together with the current production.

5.7

VISUAL ASSESSMENT OF TEMPERED GLASS - SINGLE

Checking the quality of glass and the performance of toughened, toughened / annealed and thermally strengthened panes consists of visual inspections carried out with the unaided eye in natural lighting conditions against a matte black background, screen or in transmitted and / or reflected light depending on the glass used and the corresponding technical specification / standards).

Defects invisible at a distance of 2 m (3 m for coated glass) do not qualify as defects. Assessment of toughened, toughened / annealed and thermally strengthened panes is made in accordance with Table 14.

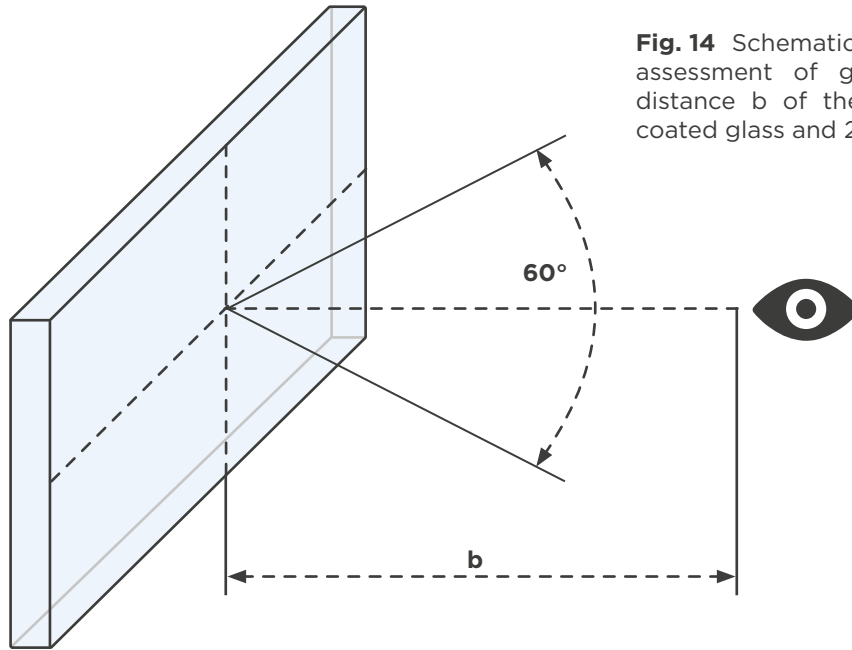

Fig. 14 Schematic diagram of the visual assessment of glass. The approximate distance b of the observer is: 3 m for coated glass and 2 m for uncoated glass.

Table 24

Specification of acceptable defects in tempered, tempered heat soaked and heat strengthened glass

Item	Defect mm	Glass surface		
		< 1 m ²	1 - 2 m ²	> 2 m ²
1	Spot - inclusions of foreign matters	Unacceptable	Unacceptable	Unacceptable
2	Air bubbles into the glass (open)	Unacceptable	Unacceptable	Unacceptable
3	Closed air bubbles (incl. spot defects up to 0,5 mm shall not be considered)	Acceptable, 2 ea. of max dim. 2 mm	Acceptable, 3 ea. of max dim. 2 mm	Acceptable, 5 ea. of max dim. 2 mm
4	Linear defects	Acceptable with a total length of 40 mm and of a single length up to 15 mm. In the peripheral zone, acceptable isolated up to 20 mm.	Acceptable with a total length of 45 mm and of a single length up to 15 mm. In the peripheral zone, acceptable isolated up to 20 mm.	Acceptable with a total length of 50 mm and of a single length up to 15 mm. In the peripheral zone, acceptable isolated up to 20 mm.
5	Edge defects	Blunt edge (machined periphery) - small splinters acceptable, provided they will be blunt; shiny areas - acceptable. Ground edge (with shiny areas) - bunt edge with trimmed face or ground - insufficiently ground shiny areas - acceptable Smoothed ground edge (no shiny areas) - ground edge - splinters, some insufficiently ground areas (shiny spots) - unacceptable Polished periphery - polish edge - dull spots, splinters - unacceptable		
6	Spots, streaks	Acceptable, if not visible from the distance specified in the standard relevant for a specific type of glass, in daylight.		
7	Defects of applied enamel	- in accordance with point 3.3 - Part II of the Company Standard		

5.8**MARKING OF HEAT TREATED GLASSES**

Marking of toughened glass (ESG), heat-soaked toughened glass (ESG-H) and thermally strengthened glass (TVG)

According to the standards EN 12150-1 toughened glass, EN 14179-1 thermally soaked toughened glass, EN 1863 thermally strengthened glass should be marked clearly and permanently.

The marking should contain information on the name with the manufacturer's trademark and the number of the EN 12150-1, EN 14179-1 or EN 1863 standard.

Fig. 15 Below are some examples of marking.

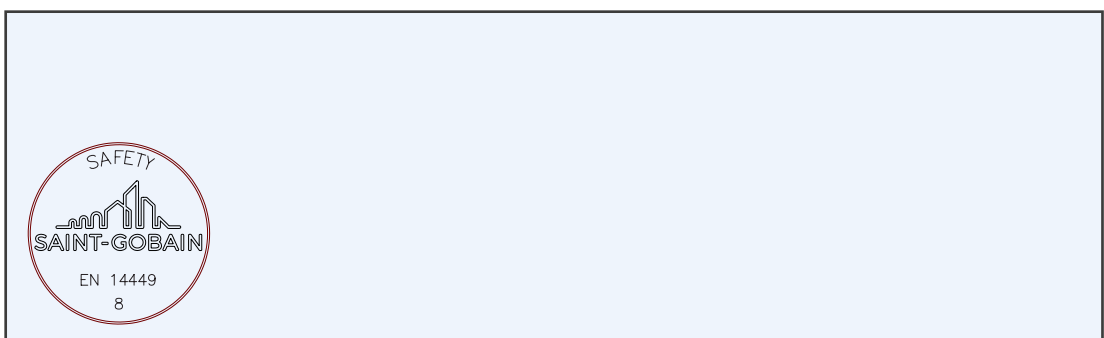
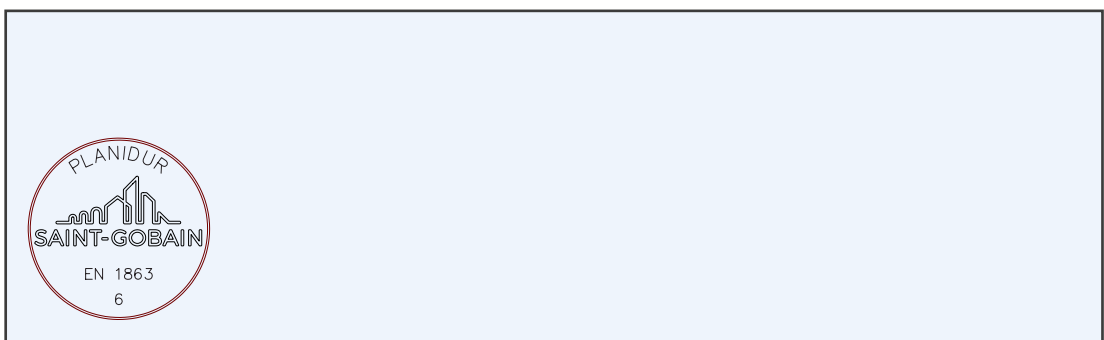
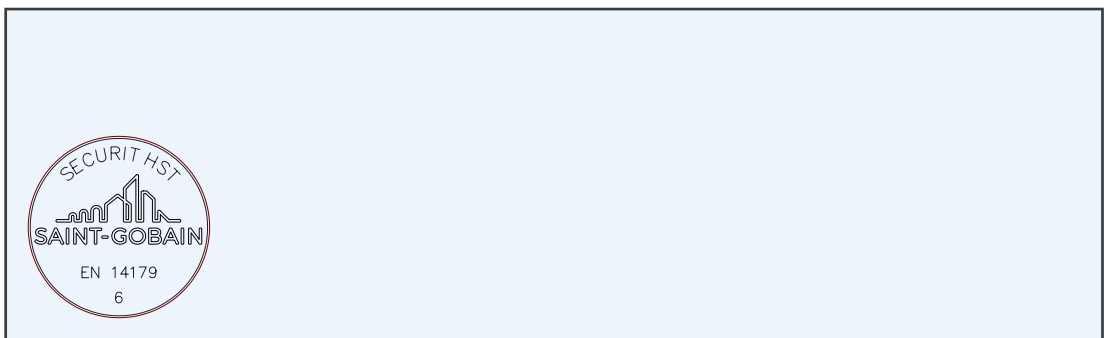
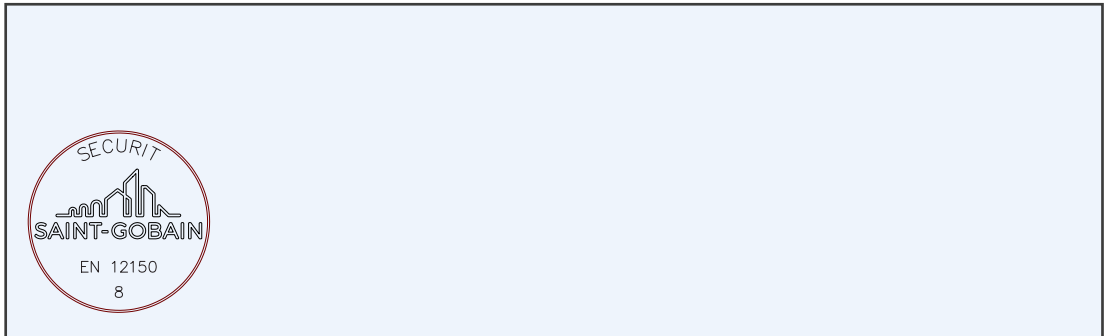

Laminated glazing

All GLASSOLUTIONS products are manufactured in accordance with the most stringent quality standards contained in the European Standard EN 14449. However, it should be remembered that the natural properties of the material, which is glass, and the many different processes that the glass undergoes in order to achieve the target functional properties, can sometimes affect the appearance of the finished product. The European Harmonized Standard (hEN) for laminated safety glass is the hEN 12543/14449 standard, which defines the quality of the final product.

6.1

DEFINITION AND CONSTRUCTION

Laminated glass is a system of two or more glass forms connected by one (or more) interlayer. The interlayer is usually made of a PVB foil - a polyvinyl-butyril compound.

Fig. 16 Construction and nomenclature of laminated glass

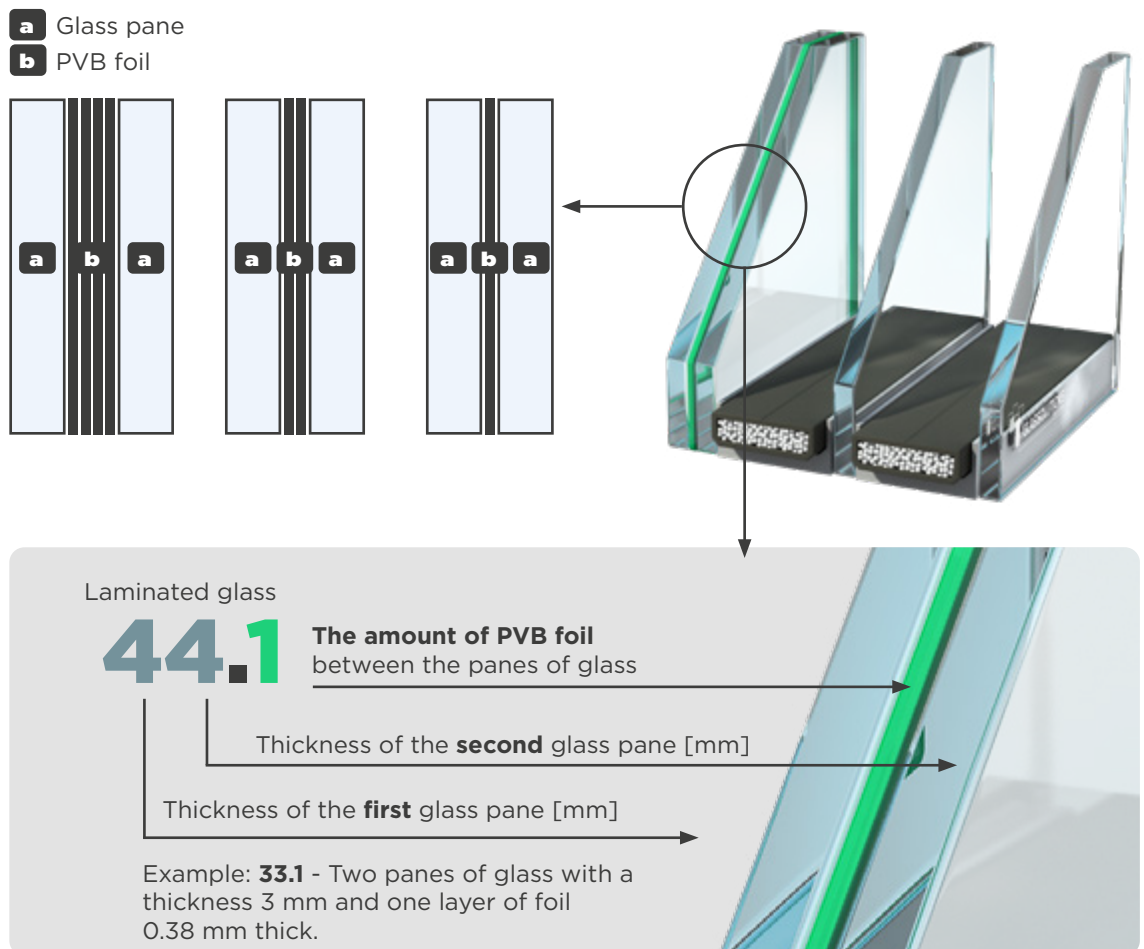

Laminated glass is safety glass. If broken, the glass shards remain on the foil, reducing the risk of injury or cuts.

The laminated glass may include any type of glass mentioned in the previous chapters, but the exact design should be agreed with the manufacturer, as there are limitations in the use of various glass coatings (e.g. enamel, special coatings or sandblasted side, etc.) in contact with the interlayer / foil.

Different types of processing of edges, holes, cutouts, etc. are possible for laminated glass according to chapter 2 subject to the limitations given in this chapter. Details should be agreed with the manufacturer. The requirements for laminated glass have been specified in the PN-EN 14449 standard and the PN-EN ISO 12543 standard series.

6.2 TOLERANCES OF EXTERNAL DIMENSIONS

Possible dimensional deviations of products with rectangular shapes are shown in the figure below.

Fig. 17 Tolerances of laminated rectangular glass

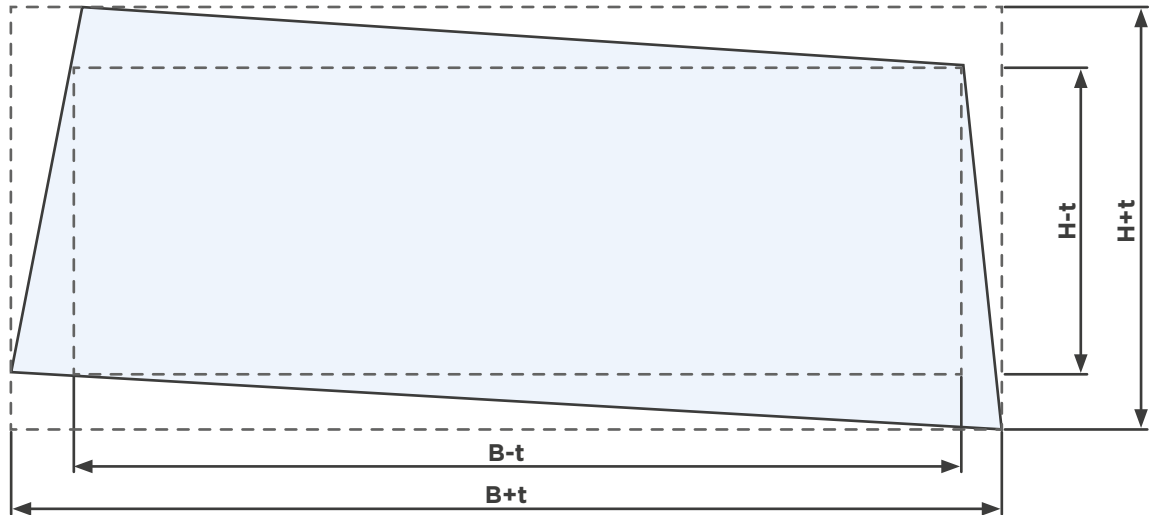

Table 25 Limit deviations for strict dimensions

Nominal dimensions B or H	Nominal thickness ≤ 8 [mm]	VSG nominal thickness > 8 [mm]	
		Each pane of glass in thickness < 10 [mm]	Each sheet of glass thickness ≥ 10 [mm]
< 1100	+2,0 -2,0	+2,5 -2,0	+3,5 -2,5
< 1500	+3,0 -2,0	+3,5 -2,0	+4,5 -3,0
< 2000	+3,0 -2,0	+3,5 -2,0	+5,0 -3,5
< 2500	+4,5 -2,5	+5,0 -3,0	+6,0 -4,0
> 2500	+5,0 -3,0	+5,5 -3,5	+6,5 -4,5

6.3 TOLERANCES OF MUTUAL MOVEMENT OF FORMATS

A normal phenomenon during the process of laminating glass panes is the mutual displacement of the composite forms, as shown in Fig. 23.

Fig. 18 Displacement of components in a laminated package

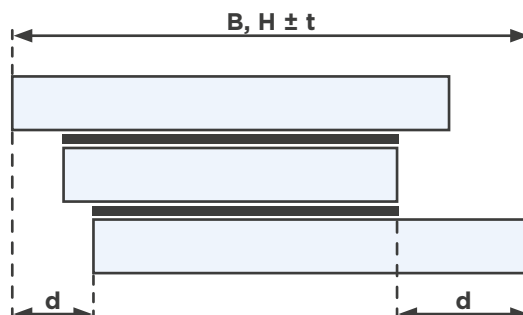

The permissible tolerances for the shift of components in an assembly consisting of laminated glass are presented in the table below.

Table 26 Tolerances for the shift

Nominal dimensions B or H	Max. allowable tolerances for the shift d [mm]
< 1000	2,0
1000 ≤ B, H < 2000	3,0
2000 ≤ B, H < 4000	4,0
B, H ≥ 4000	6,0

In the case of laminates made of glass components that are not heat-treated, it is possible to process the edge of the glass after lamination in order to improve the visual effect and eliminate any stepped edge.

6.4

PACKAGE THICKNESS TOLERANCES

The thickness of the laminated package may not exceed the sum of the thicknesses of the individual sheets, considering the inner layer (thickness tolerances of individual components in accordance with PN-EN 572).

Interlayer variations are not taken into account if the overall nominal thickness of the interlayer is <2 mm. If the interlayer thickness is ≥ 2 mm, the interlayer thickness tolerance of ± 0.2 mm shall apply.

Glass and interlayer tolerances in laminated bundles add up.

The glass is visually inspected when viewed vertically and parallel to the dull gray screen, at a distance of approximately 2 m (for coated glass - 3 m), in front of the pack, under bright, diffused daylight or equivalent lighting (care should be taken to ensure that the package was not in direct sunlight). The following factors should be considered in the visual evaluation:

- size of the defect,
- frequency of defects,
- size of the tested glass,
- the number of sheets included in the package.

Cracks are not allowed.
The appearance of wrinkles and streaks in the field of view is not allowed.

For the inner layer made of colored PVB foil, there is a risk of loss of color intensity over time due to UV radiation. This type of phenomenon in the form of color differences does not constitute grounds for a complaint.

6.5

VISUAL ASSESSMENT OF LAMINATED GLASS



6.6 PRODUCTION POSSIBILITIES

Table 27 Laminated glass VSG - possibilities

Laminated glass VSG		
mm	Standard	Complex
Glass thickness	33.1-1515.4	up to 85mm
Min. size	400x400	100x100
Max. size	2500x4400	2600x4500 lub 1200x5000
Max. weight	400	800

Table 28 PVB selection guidelines

PVB selection guidelines								
VSG laminated glass		Minimal PVB foils quantity						
Glass type	Glass type	FLOAT			ESG			TVG
	Glass thickness [mm]	≤ 6	8, 10, 12	15 i 19	4, 5	6 ÷ 15	19	≤ 12
FLOAT	≤ 6	1	2	4	4	4	6	4
	8, 10, 12	2	2	4	4	4	6	4
	15 i 19	4	4	4	4	4	6	4
ESG	4, 5	4	4	4	2	4	6	4
	6 ÷ 15	4	4	4	4	4	6	4
	19	6	6	6	6	6	6	6
TVG	≤ 12	4	4	4	4	4	6	4

Table 29 Tempered glass lamination with 2 PVB foils

Laminated glass with tempered glass with 2 PVB foils								
	ESG + ESG	PVB 0,76	Holes	Cut-outs	Models	Min. dimensions	Max. dimensions	Side ratio
44.2	X	X	X	X	X	400x400	1300x2000	1:10
55.2	X	X	X	X	X	400x400	2000x3300	
66.2	X	X	X	X	X	400x400	2100x3800	
66.2	X	X	-	-	-	400x400	2200x4400	
88.2	X	X	-	-	-	400x400	2425x4400	

Table 30 Lamination of toughened soft-shell glass.

Tempered soft coat glass lamination							
	ESG PLC	ESG TF	PVB 1,52mm	Models	Min. dimensions	Max. dimensions	Side ratio
44.4	X	X	X	X	400x400	1200x2100	1:10
66.4	X	X	X	X	400x400	1500x3500	
	X	X	X	X		2000x3000	
88.4	X	X	X	X	400x400	2400x4500	
Notes	Glass has to be the same thickness One 1,52 mm foil layer is necessary After lamination soft coat grinding along edge Tempering and lamination on precess engineer probation						

Table 31 „Coat to foil” lamination

Allowed glasses		
Glass type	Możliwość laminowania	
ANTELIO STOPSOL	Yes	
ST 120 ST 136 ST 150	Yes	
STB 120 STB 136	Yes	
MIRASTAR	Yes only with PVB Solutia	
SKN 154 165 174		No
Xtreme 60-28		No
PLANITHERM		No
PLANISTAR		No

Table 32 Lamination with Silk-screen printing

Lamination with silk-screen printing			
Print color	Paint reference nb.*	Lamination possibility	Price increase**
FERRO palette (ETC)	Individual for every print color	Yes	33%

***NOTICE** Paints are on individual orders (supplier ETC), it can affect on realization time.

** **33%** price increase compared to standard RAL paints from TES company

Table 33 Foil colors list

Foil standard colors list - VANCEVA				
VANCEVA PVB name	Ref.nb.	Color	Lt [%]	Solar factor g
Clear	0	Transparent		
Cool White	A	White mat half-transparent	81	0,75
Deep Red	C	Red-cherry	15	0,49
True Blue	D	Niebieski	14	0,53
Tangerine	E	Orange	42	0,62
Polar White	F	White non transparent	7	0,19
Absolute Black	G	Black non transparent	0	0,25
Ocean grey	H	Grey-brown	61	0,67
Coral Rose	1	Bright pink	79	0,79
Aquamarine	2	Azure	77	0,78
Smoke Grey	3	Bright grey	78	0,76
Sahara Sun	4	Yellow	78	0,73
Ruby Red	5	Red-pink	51	0,71
Sapphire	6	Blue	49	0,66
Evening Shadow	7	Dark grey	49	0,61
Golden Light	8	Bright yellow	85	0,78
Arctic Snow	9	White mat	68	0,67

NOTICE Standard VANCEVA foil roll is 1590 mm, thickness is 0,38 mm

Laminated glass with Sentry Glass foil (anti-hurricane)	
Foil	Sentry Glass 0,89 mm, 1,52 mm, 2,28 mm Folia specjalnie zamawiana co ma duży wpływ na termin realizacji
Dimension	max. 2140x3660 mm, min.400x400 mm
Wholes and cut-outs	Yes
Edge wored	min. grinding
Printed glass	only paint Ferro ETC
Notes	The tin side of the glass should face the foil Removing excess 1,52 and 2,28 mm foil using a grinder

Table 34 Application of PVB foil

Application of PVB foil used in Pruszków plant						
Foil parameters				Application		
Producer	Mark	Type	Thickness [mm]	Glass Typr	Application	Limits
TROSIFOL	BG-R15	Clear	0,38	TVG, ESG	inside & outside	Matching with mat foil
SOLUTIA	RB 11	Clear	0,38	FLOAT, TVG, ESG	inside & outside	None
	RB 41		0,76			
	RB 61		1,14			
	RB 71		1,52			
SOLUTIA	QS 31	Silence	0,63	FLOAT	inside & outside	2 SILENCE foils can't be matched
	QS 41		0,76 oraz 1,52	FLOAT, TVG, ESG		
TROSIFOL	BG-R15	White mat	0,38	FLOAT, TVG, ESG	inside & outside limited	Outside application only in frames
			0,76			It is forbidden to use in thermal treat (TVG) or silk-screen printing in outside application
SOLUTIA	VANCEVA COLOR/WHITE	Cool White A	0,38	FLOAT, TVG, ESG	inside & outside	None
		Deep Red C				
		True Blue D				
		Tangerine E				
		Polar White F				
		Absolute Black G				
		Ruby Red 5				
		Sapphire 6				
		Evening Shadow 7				
		Golden Light 8				
Arctic Snow 9						
SOLUTIA	VANCEVA DESIGN COLOR	Color Rose 1	0,38	FLOAT, TVG, ESG	inside	Only for internal use
		Aquamarine 2				
		Smoke Grey 3				
		Sahara Sun 3				
		Ocean Grej H				
SOLUTIA	DG 41	Clear Strong	0,76	FLOAT, TVG, ESG	inside & outside	None
TROSIFOL	SENTRYGLASS PLUS	Clear Strong	0,76	FLOAT, TVG, ESG	inside & outside	None

Compatibility of materials

Glass for use in construction and construction works comes into direct and indirect contact with materials and assembly materials, sealants, cleaning agents, etc. Insulated glass, laminated or toughened glass also contains chemicals such as PVB foil, internal sealing / external sealing. These products should be tested and found to be compatible with each other.

The customer should ensure that the mounting materials and cleaning agents used will not react physically or chemically with the ordered product. This reaction may occur after a short, medium or even long time of use, changing the structure, color or consistency of the glass components.

Even materials that do not come into direct contact with the glass can interfere by migrating, for example, vapors.

If necessary, the manufacturer can provide information on what materials are included in the ordered products made of composite, laminated or toughened glass. It is the customer's responsibility to select the appropriate mounting materials.

The photos below show examples of the use of incompatible mounting measures, which resulted in the migration of the sealant into the interior of the joint.

Fig 21 The effect of using incompatible materials.



Selection of glass to be used - NORMS

Products manufactured by Saint-Gobain Polska Sp. z o.o. The GLASSOLUTIONS branch in Jaroszewiec (hereinafter: Saint-Gobain Glassolutions) are manufactured in accordance with EN standards for the production of glass (respectively: composite, laminated, tempered, etc.), which is also indicated in the General Sales Conditions / General Warranty Conditions (available on the website www.glassolutions.pl/warunki).

At the same time, we would like to point out that the selection of glazing for a given investment lies with the architect / designer / constructor of a given facility, where already at the design stage they should be considered, inter alia, structure loads, location, influencing, inter alia, wind load, exposure to high temperatures, glazing size. In addition, the selection of glass is also influenced by the use and function of glass in a facility as well as the purpose and method of use of the building itself - including whether the building is intended for housing (single or multi-family) or is a public building.

In the case of building glass, the rules for the selection of glass may, depending on the country, be determined by local legal regulations, EU standards, industry standards, etc. In Germany, this is specified in the TRAV / DIN 18008-4 standard.

In the case of Europe, it is the architect / constructor / designer who will determine the choice of glazing to be used in an investment. In the case of Poland, it is most often performed on the basis of the Guidelines of the Building Research Institute (the series of Instructions, Guidelines, Handbooks - issue No. 488/2013 Construction glass elements) or the so-called Eurocodes, i.e. a set of European standards defining the principles of designing and constructing building structures and methods of verifying the features of construction products of structural significance, in force in the Member States of the European Union on the basis of the Harmonization Document.

As a manufacturer of construction glass and insulating glass - we confirm that the product supplied by us - construction glass was in accordance with European standards for the production and quality of construction products, i.e.:

- **PN EN 1279-1** „Glass in building. Insulating glass units. Part 1. General requirements, dimensional tolerances and system description rules. „ - Double glazing
- **PN-EN 12150-1** „Glass in building. Thermally toughened soda lime silicate safety glass. Part 1: Definitions and Description. „ - Toughened glass sheets
- **PN-EN 572-8** „Glass in building. Basic soda-lime-silicate glass products. Delivering products with strict dimensions. „ - Float glass sheets
- **PN-EN 1096-1** „Glass in building. Coated glass. Part 1: Definitions and classification. „ - Coated glass sheets
- **PN-EN 14449** „Glass in building - Laminated glass and laminated safety glass” and other related standards.

Due to the fulfillment of the above-mentioned standards, Saint-Gobain Glassolutions glass products can be taken into account for use in construction works and calculations in accordance with e.g. DIN18008 or the historical TRAV / TRLV standard, while the appropriate selection of glazing for the investment should be made by the architect / constructor on the basis of appropriate calculations and analyzes of the specific conditions of a given investment.

In case of any questions, we remain at your disposal.

GENERAL suggestions for WINDOWS – **they are not the basis for the selection of glazing** *:

1. For frame / timber structures with building movements - toughened glass
2. Glazing where pressure compensation is required (altimeter) - toughened glass
3. If there is a risk of hitting a ball (from the outside) - toughened glass + laminated glass
4. Glazing flush with the floor, i.e. less than 90cm and Low fall height in case of falling through the glass (exit to the terrace) - toughened glass or 2B2 i.e. 33.1
5. Glazing flush with the floor, i.e. less than 90 cm, and Risk of falling from a great height / falling out „through the window” - laminate 1B1, i.e. 44.2
6. Sound insulation - laminate 33.1 or better
7. „Normal window” - hardened / float or laminate 33.1 or better
8. Store windows - laminated glass
9. Offices - walls / doors - tempered, laminated or fire glass
10. Hotels / lobby - tempered glass + sound-absorbing glass
11. Kindergartens / nurseries - toughened glass + sound-absorbing glass
12. Hospitals - tempered glass + sound-absorbing glass
13. Shopping centers / shop windows in shopping centers - tempered glass
14. Public car parks - tempered glass
15. Bus stops - tempered glass
16. Pools - tempered glass (risk of ball hitting), heating glass (no condensation)
17. Gymnasiums - tempered glass (risk of hitting a ball)
18. Squash rooms - tempered glass - min. 12mm
19. Sound-absorbing screens - laminated glass or toughened glass + HST (heat soak test)
20. Glass door - tempered glass
21. The facade is mounted on the so-called „Spider” laminated glass consisting of at least two panes of semi-toughened glass
22. Roof windows with an area of less than 1.6 m2 - laminated glass made of float glass
23. Glass canopies - laminated glass consisting of at least two panes of semi-tempered glass, glass with a shading function

*** In each case, the responsibility for the selection of glazing rests with the Architect / Constructor, and not the manufacturer of the window joinery or the manufacturer of the glass.**

*** The selection of glass is carried out by the Architect taking into account the structure of the building as well as wind pressure and atmospheric factors + static and dynamic loads**

At the express request of the client, Saint-Gobain Polska Sp. z o.o., (Glassolutions is brand) can carry out load calculations for the glazing used in a given geographical location.

9

Polishing the glass surface - scratches

Any modifications of insulating glass units, including glass polishing - without prior agreement and supervision by Saint-Gobain Polska - constitute a modification of the construction product. Such third-party modifications may result in:

- loss of mechanical properties
- optical distortions
- tarnishing the glass over time
- deterioration of the insulating conditions of insulating glass units

The result of these modifications, i.e. glass polishing made by a third party without the consent and supervision of Saint-Gobain Polska, causes:

1. Loss of guarantee for insulating glass units by Saint-Gobain Polska;
2. Loss of the CE marking for the construction product which is insulating glass.

In the light of legal liability and European standards EN1279 - the ordering party and a third party making such a modification without agreeing with the manufacturer takes responsibility for the use of a construction product without CE marking.

10

Glass corrosion

Glass is an interconnected material on the surface of which a protective layer of oxides is formed. When the surface of the oxides is damaged during inspection in the case of strong lighting or, for example, with the use of steam - it is indeed possible to reveal the characteristic phenomena on the glass, which is a known case in the glass industry. These phenomena identified as glass corrosion resulted from the contact of masonry / structural plaster / paint etc. with the surface of the glass or label residue.

Labels should be removed from the glass surface within a maximum of 3 months from the date of glass delivery - otherwise, the glass may corrode as in the case of contact with the above-mentioned building materials. This corrosion is often „greasy” contained in the materials used for plastering will damage the glass surface, unless it is removed immediately with a sponge and plenty of water.

ATTENTION Advanced glass corrosion cannot be removed by the following method, the glass is permanently damaged.

1. If the glass surface is already damaged, e.g. by splashing the glass with paint that has not been removed immediately - commercially available glass cleaning agents, e.g. Cif / Cilit, etc., may accelerate this corrosion and increase this type of phenomenon - giving the impression - that the defects or “greasy glass” cannot be removed.
2. The instructions for the installation / cleaning of the glass surface - available on the website, must always be followed www.glassolutions.pl/pl/warunki



An example of corrosion on glass in the form of plaster dots

3. We can try to remove glass corrosion using a professional 3M Glass Polishing Compound cleaning agent and steel wool. A drop of 3M agent should be placed on a piece of 0000 wool and evenly spread over the glass surface, let it dry. Then remove excess of the dried agent with a second (clean) piece of wool. Operation time approx. 30 seconds. Note - Please read the directions for use provided by 3M before use.
4. Excess agent can be removed with water and isopropyl alcohol.



Steel wool granulation
000 np. Stahlwolle RAKSO



A special liquid for cleaning glass



**The use of coarser granulation wool may damage the surface.
If corrosion is advanced, the above-mentioned agent will not work.**

ATTENTION!
Too brutal and local application of the agent can lead to the appearance of optical distortions.

10.1

REMOVING CONDENSATION PATTERNS

The corrosion removal method can also be used to attempt to remove water condensation patterns. The patterns formed on the surface of the glass by water / moisture condensation are known as „drip patterns” / suction pad marks. They are not a defect of the glass. They are formed due to the presence of microscopic silicone deposits on the glass surface, which decompose over time.

In case the new IG unit is installed close to the old glass, the glass surfaces in these glass panes will have a different age, so condensation / moisture may create different patterns on them.



10.2

REMOVING LABELS / CLEANING THE GLASS SURFACE

Glass cleaning should be carried out by the usual washing method, using plenty of water, a sponge, a rubber squeegee, soft leather or a commercially available spray-on cleaner.

Sharp tools such as razor blades or scrapers may slightly scratch the surface and should therefore be avoided. It is imperative to immediately remove lumps of cement or other remnants of building materials, otherwise it may lead to irreversible damage to the glass surface.

If sealant remains on the glass during sealing work, remove it immediately. Difficult to remove dirt, e.g. paint or tar stains or adhesive residues, should be removed with the use of appropriate solvents, i.e. spirit, acetone or gasoline, and then the glass should be washed with water.

Labels and cork spacers should be removed from the glass surface within 3 months from the date of manufacture of the glass. The adhesive on the labels has special properties that prevent it from leaving any traces on the glass when the labels are peeled off within a certain time period (up to 3 months). If the label is removed after 3 months, the label adhesive will degrade. This is most often caused by the exposure of the anastomosis and the label on it to UV radiation. Consequently, the label becomes difficult to remove from the glass surface. Removal of the remnants of stickers and spacers should be performed by the contractor with the use of the cleaning agents described above. You should also try to wet the label several times - within 1 hour before trying to remove the label.

As a result of leaving the label on the glass for more than 3 months from the production date, glass corrosion may appear - you can try to remove the traces of the label using the above-mentioned method using 3M paste and steel wool.

It is forbidden to use any hard objects (metal / wood / plastic) when trying to remove the label - they can scratch the glass.

Surface condensation will appear on face 1 of the insulating glazing if the temperature on this face of the glazing is significantly lower than the external air temperature and if the dew point (i.e. temperature at which water vapor becomes liquid) of the external air is higher than the temperature of the glass. This does not indicate that the assembly is defective but rather shows that the unit and the Low E coating is working effectively. The condensation will disappear as the sun rises and warms the glass, but the incidence can be minimized by using SGG VIEWCLEAR® Anti Condensation glass. SGG VIEWCLEAR® II is a glass designed to significantly reduce the number of external condensation days impacting upon an insulating glazing unit. It can be combined with many other high performance low-E products from the Saint-Gobain Glass range. It is also possible to spray the windows with a water repellent spray.

More information is available in the Glass Surface Cleaning Instruction, ed. 04.2017 available on the website www.glassolutions.pl

11**Butyl flashings****11.1 SEALANT COMPATIBILITY**

We would like to assure you that in order to maintain the highest standards, our products are regularly tested. Primary and secondary sealing compounds used in Glassolutions (Butyl and Outer sealant) - regularly inspected, comply with the requirements of EN 1279 - this is confirmed by external and internal tests, as well as numerous certification audits.

The silicones and assembly adhesives available on the market are not always compatible with the EN1279 sealants used by Glassolutions. Additionally, they are often characterized by changes in chemical composition over time, which results in the lack of a permanent compatibility list on the market.

11.2 INTERNAL SEALANT OUTLET

The outflow of the internal sealant, i.e. butyl, can be divided into two types. There are chemical and thermal outflows. Chemical flashes are related to the incompatibility of the assembly adhesives or silicones used with the sealing compounds used by Glassolutions.

On the other hand, thermal outflows are most often associated with factors causing mechanical loads resulting from the natural movements of the glass

11.3 CHEMICAL BUTYL FLOW

Glass for use in building and construction works comes into direct and indirect contact with materials and assembly materials, sealants, cleaning agents, etc. These products should be tested and found to be compatible with each other. The customer should ensure that the mounting materials and cleaning agents used will not react physically or chemically with the ordered product (eg through consultation with the Glassolutions Quality Department). This reaction may occur after a short, medium or even long time of use, changing the structure, color or consistency of the glass components. Even materials that do not come into direct contact with the glass can interfere by migrating, for example, vapors.

If required the IGU manufacturer can provide the data on the materials used in the IGU and recommended fixing materials. It is the customer's responsibility to select the appropriate assembly materials. The photos below show examples of the use of incompatible mounting measures, which caused the migration of the sealant into the interior of the fixation. The photos below show examples of chemical spills - they are typically pinpoints and can cause oily streaks



11.4 THERMAL BUTYL FLOWS

In specialized literature, thermal flashes from the internal sealant are referred to as the „creeping butyl” phenomenon.



Insulating glass units during their service life are exposed to various factors causing mechanical stress:

- solar radiation (especially with coated glass) can increase the temperature and pressure of the gas,
- wind pressure on the facade,
- snow pressure on the roof,
- own weight.

Due to the temperature difference OUTSIDE between night and day, the double glazing located inside the frame „works” all the time. The amount of flexing from concave to convex can be calculated using the coefficient of thermal expansion.

The IGU can therefore be likened to an „air pump”. Since this „pump” is tight, the pressure inside the unit may increase and decrease, which means that the dimensions of the glass panes will change every day. This phenomenon, in turn, directly translates into movements of the inner sealant.

This is a natural effect as the butyl / glass connection and frame are only physical connections (van der Waals forces

Outside

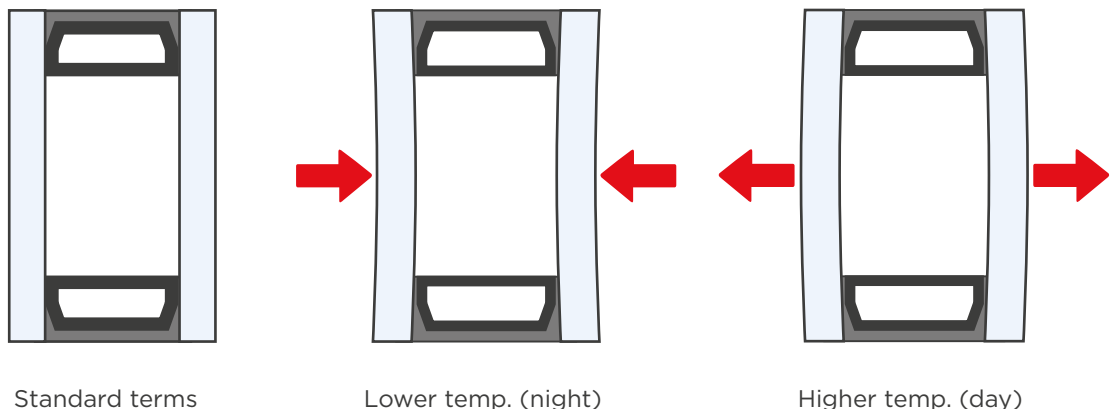
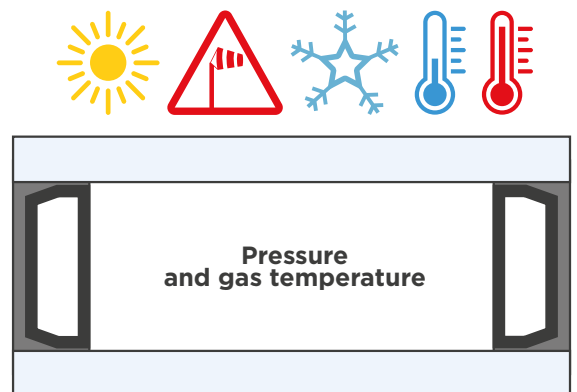

Fig. 19

12

„Ringing” of georgian bars

Under the influence of weather conditions, the georgian bars may sometimes deform from a straight line, they may appear discolored, or they may knock against the glass. Neither of the above cases is classified as a defect. These phenomena intensify with the increase of the dimensions of the glazing unit. When the temperature returns to normal, the bars will return to their original settings. Any visible discoloration of the slats is usually caused by the coating on the glass. The knocking of the slats against the glass (a ringing phenomenon) may be noticeable in certain weather conditions where the IGU is exposed to external vibrations. This means that the georgian bars bar may vibrate when opening / closing the window. Additional factors are weather conditions, e.g. strong gusts of wind, and the location of the building / building structure / method of installing windows. In the case of a busy street, we will experience vibrations differently. The use of the so-called bumpons are designed to protect the glass from damage, not to completely eliminate vibrations. Bumpons reduce the ringing effect of the georgian bars, but do not eliminate it.

Neither of the above cases are classified as a defect. This phenomenon increases with the size of the glazing unit and the number of georgian bars in the unit.

The slots and georgian bars are installed with a position tolerance of ± 2 mm in relation to the inner edge of the spacer.

In the case of arched top panes or panes manufactured according to a template, the deviation of the georgian bars from the dimensions may increase up to 10 mm.

„When georgian bars are used in two chambers of a double-glazed unit, the dimensional tolerances for the division of the georgian bars are ± 4 mm.”

„When making oblique georgian bars, the deviation may amount to ± 5 mm due to the hand-made method.”

13

Concave and convexity of the glass

The glazing unit closed with a seal contains a specific volume of gas in the space between the panes. The output of the gas is determined largely by the barometric air pressure, the absolute altitude and the air temperature at the time and place of production. When insulating glass is installed at different heights, concave and convex bends of the individual panes inevitably arise with changes in temperature and deviations in atmospheric pressure and thus optical distortions. The occurrence of this phenomenon proves that the panes are well-made - they are simply tight. This phenomenon is often more pronounced in unfinished buildings where the building is still unheated.

Example of concave glass panes:



For the installation height of the glass unit above 700 meters above sea level - it is necessary to inform the Manufacturer about the height of the installation in order to check the necessity to compensate the pressure in the unit or the necessity to change the structure. Cracks due to concavity and convexity as well as unsealing of the insulating glass unit installed above 700 meters above sea level, which was not subject to compensation, are not covered by the warranty. The physical properties of the glass and the structure of the insulating glass determine some specific properties of insulating glass and single glass, which are not defects, are not subject to complaint and are not covered by the warranty - these phenomena are described in the General Warranty Conditions and in related documents.

Details of this phenomenon are described in the PN-EN 1279-1 Standard - Annex C - Optical and Visual Quality of Glazing.

The limit above 700 meters above sea level - with the necessity to perform pressure compensation or a change of construction - results from the fact - the lower fracture resistance of IGUs to „stretching - convex” than „compression - concavity”. On the other hand, pressure compensation - does not eliminate this phenomenon (concavities and convexities).

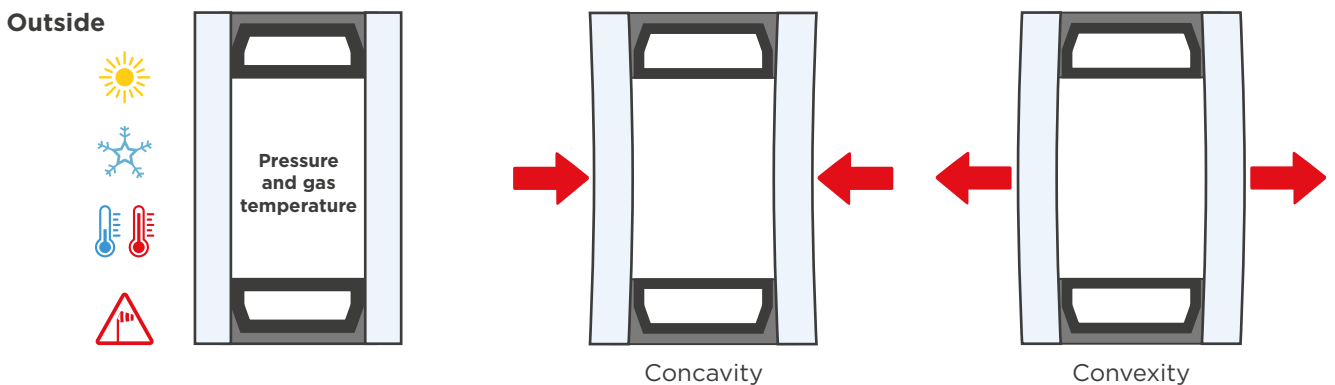

Fig. 20

If the glazing is installed at a height of less than 700m above sea level - there is no risk of cracks, but the phenomenon of concavity may occur. The concavity / convexity phenomenon, apart from atmospheric conditions - pressure and temperature, is also influenced by the tolerance of the window frame dimensions in relation to the glass insert, as well as the pressure of the building structure on the frame - it is described in detail in PN-EN1279-5 - Annex C - Installation of Insulating Glass Units as well as in prEN ISO14439 / prEN12449 MEASUREMENT acc. to EN12150 and EN1279

Measurement of concavity / convexity / undulation of single and composite glass - always when the glass is vertically positioned, supported at two points.

ATTENTION!

Such measurements must not be made when the glass is lying flat (in a horizontal position). Single and double glazing cannot be placed in the frame during the measurement of the window

a) **Fig. 21** Vertical position

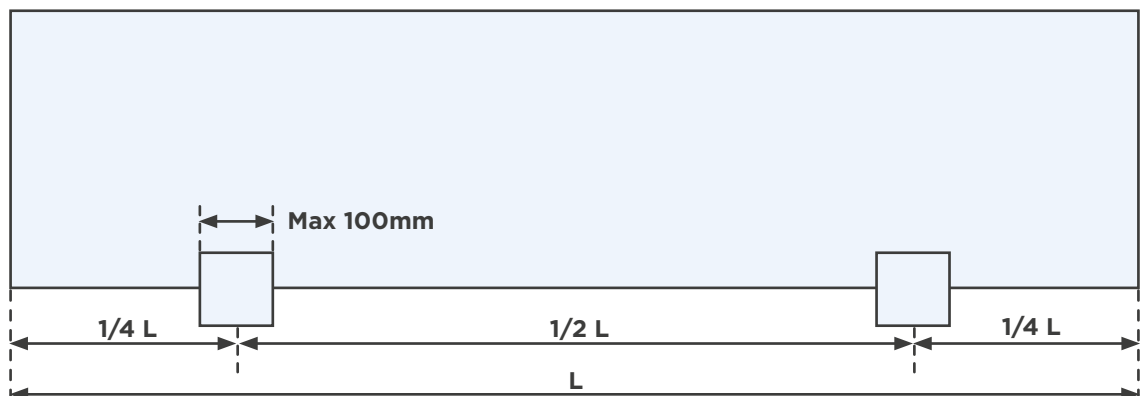

b) **Fig. 22** Measurement of the local convexity (glass wave) of a single glass
Specification - max 0.3mm / 1000mm according to EN 12150

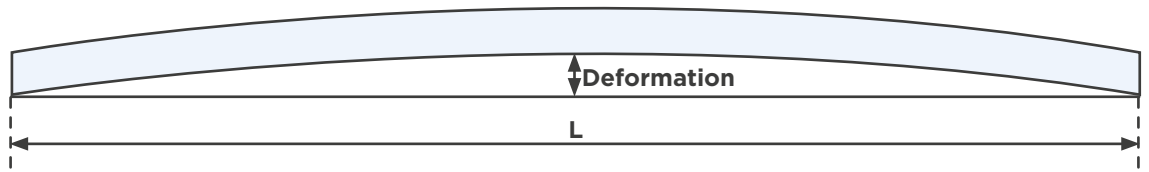

c) **Fig. 23** Measurement of the local convexity (glass wave) of a single glass
Specification - max 0.3mm / 1000mm according to EN 1215



d) Measurement of concavity and convexity of the insulating glass unit according to EN1279: G5
Specification: no limit, natural phenomenon.



After installation - the bulge is always without EN1279 G5 limit in all of the following cases.

- Glass panels without pressure compensation
- Altimeter (minimizes but concavity-convexity is present)
- Capillaries (minimizes but there is concavity-convexity)
- SWS Air (minimizes but there is concavity-convexity)
-

ATTENTION! Insulated glass, depending on the type and size, will have a different concavity - Convex. Failure to compensate or poorly selected glass for the application may, in extreme cases, lead to cracks.

Concavity and convexity of IG units are a natural phenomenon and are not covered by the warranty.

Pressure compensation

The pressure compensation in the IG unit is performed to minimize the phenomenon of glass breakage resulting from the concavity or convex phenomena of the IG unit related to pressure and temperature differences at the production site, and to minimize the phenomenon of glass lensing. Pressure compensation reduces the concavity or convexity of the glass but does not completely compensate for it.

When using wooden, skeletal, Scandinavian or other structures, where there are building movements and the pressure of the structure on the glass absolutely, always use tempered glass. In such cases, pressure compensation may not be effective in minimizing the risk of glass breakage and reducing the phenomenon of concavity or convexity.

14.1

IMAGE REFLECTION, CONVENTION AND CONVECTION PHENOMENON

Due to the fact since insulating glass units consist of more than one glass pane, a person looking at the glass may notice multiple reflections. This effect will be more pronounced in triple insulating glass units (TGU). However, this is not a defect of the glass.

14.2

DISTORTION IN REFLECTION

The hermetically sealed space between the panes contains a fixed volume of air / gas, depending on the temperature and atmospheric pressure at the time of joining. After the installation of the glass, changes in the outside temperature and pressure will result in an increase or decrease in the volume of air / gas in the space between the glass panes, which in turn will cause the glass pane to bend visible in the form of a distorted reflection image. This distortion indicates that the glazing has been properly sealed and is not a sign of a glass defect.

Glassolutions offers various solutions for air / gas pressure compensation inside the inter-pane (IGU):

1. Altimeter
2. Capillaries
3. Valves
4. SWISSPACER Air

Data necessary to complete the order

ALTIMETR

Pressure compensation is carried out using a dedicated device, the so-called Izo-altimeter. Thanks to this device, the pressure in the double glazing will be like the conditions in the place of installation. If this solution is used, it is necessary to meet the minimum requirements listed below.

The current requirements for the implementation of orders for glass with pressure equalization, the so-called Altimetr:

- required for installation heights of glass / windows above 700 m above sea level.
- required for the relative height difference between the production site (Glassolutions) and the installation site greater than 500 m above sea level.
- all glass panes in the unit must be TEMPERED
- maximum installation height: 2500 m above sea level
- max. Transport altitude 3000 m above sea level
- the choice of glass thickness for the application / building is the responsibility of the architect-constructor
- selection of the thickness of the glass to the conditions in the place of installation (wind load) and the maximum transport height (atmospheric pressure) and to the building structure - verification within the scope of the client (design office, architect)
- minimum thickness of the spacer frame - 12mm

- the installation of georgian bars is allowed up to a height difference of 1400 m with the use of tempered glass only and the required difference of 6 mm between the thickness of the frame and the georgian bars. Example: 8 mm georgian bars, 12 mm frame, 12-8 = 4 mm, unacceptable and the need to use a 14 mm frame.
- we do not compensate for glass with CEKAL certificate

Data necessary to complete the order:

- Max window installation height (m above sea level),
- Average annual temperature at the place of installation,
- Max operating temperature in the room,
- Average temperature in use in the room,
- Maximum road transport height (m above sea level).

ATTENTION!

- The calculations performed by Glassolutions consider the relative height difference between the place where the IG unit is produced / where it is installed / transport height / and the average annual temperature.
- Pressure compensation is performed to minimize the glass breakage phenomenon due to the concavity / convexity phenomenon of the IG unit related to pressure / temperature differences at the production site and to minimize the glass lensing phenomenon.
- Pressure compensation reduces the concavity / convexity of the glass but does not compensate for it.
- When using wooden / frame / Scandinavian or other structures, where there are building movements and the pressure of the structure on the glass - absolutely, always use tempered glass. In such cases, pressure compensation may not be effective in minimizing the risk of glass breakage and reducing the concavity / convexity phenomenon.

The pressure compensation system of the glass panes requires 1-2mm of external sealant to be applied to the installation site of the plug in the spacer. It should be remembered not to cut off these risers, and to plan the placement of the washers so that they do not interfere with the installation in the window frame.

CAPILLARIES

In the case of using the so-called „capillaries”, i.e. an open system - allowing for natural pressure compensation in the insulating glass package, they are not covered by the warranty for tightness and gas content. The customer is obliged to secure / bend the capillaries after the assembly is delivered to the place of installation. The other terms of the guarantee remain unchanged. In order to reduce the risk of loss of tightness when using a capillary, the manufacturer suggests using the diagram below where a capillary is provided on the top edge of the IG unit.

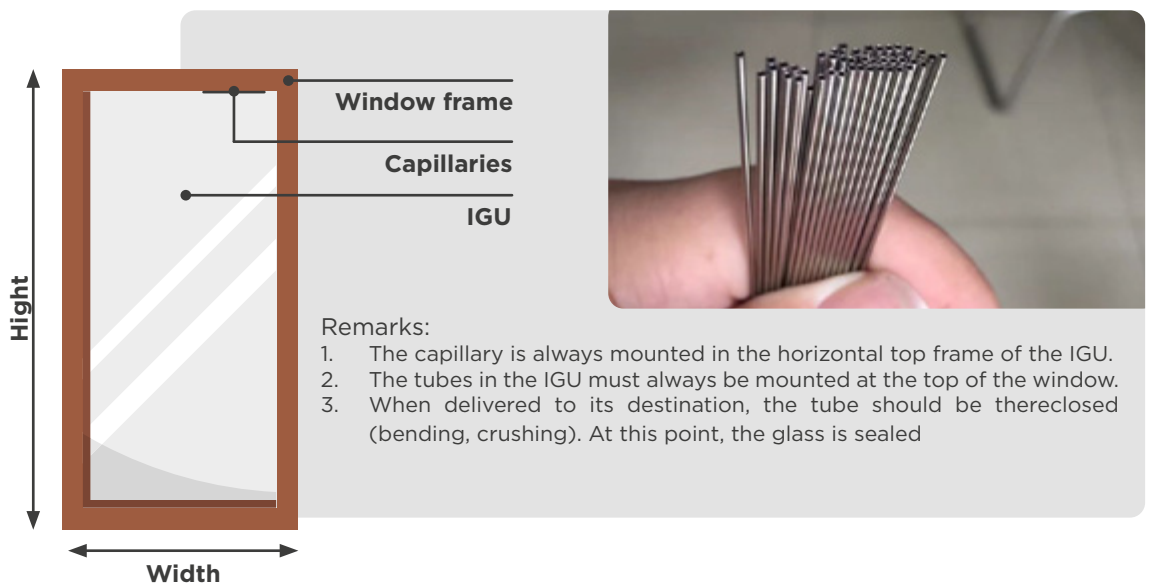

VALVES

Where there is limited information on the atmospheric conditions the air pressure can be equaliser using valves which can also be used when the method of transportation route has high or low altitude areas. The use of this method requires a written agreement with Glassolutions on the conditions of its implementation, in particular the place of installation.

STEP 1

The valve is installed in Glassolutions

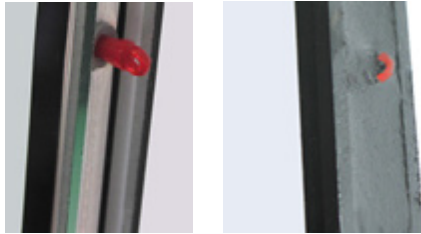

STEP 2

Valve pulled out during installation on site for pressure compensation (approx. 60 seconds)



STEP 3

Anastomosis sealing plug



STEP 4

Plug sealing



SWISSPACER AIR

When SWISSPACER air is used, it is an open system - allowing for natural pressure compensation in the insulating glass package, limiting the ingress of moisture into the insulating glass unit, such units are not covered by the guarantee of tightness and gas content (the panes contain air). The use of this method requires a written agreement with Glassolutions on the conditions of its implementation, in particular the place of installation.

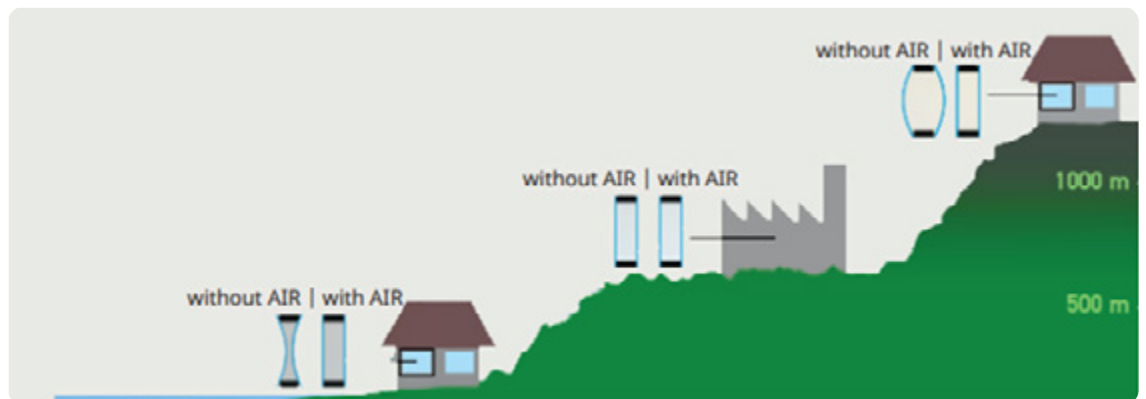

Fig. 24

Heat Soak Test - Nickel Sulfide



DESCRIPTION OF THE PHENOMENON

The photographic documentation of the complaint panes attached above shows a typical case of spontaneous rupture caused by Nickel Sulfide. This phenomenon is widely described in the industry literature.

A naturally occurring contamination present in all glass is nickel sulphide contamination. It is rare, but in some cases it can lead to the spontaneous breakage of the toughened glass during its use.

Nickel sulphide has no effect on the annealed float glass.

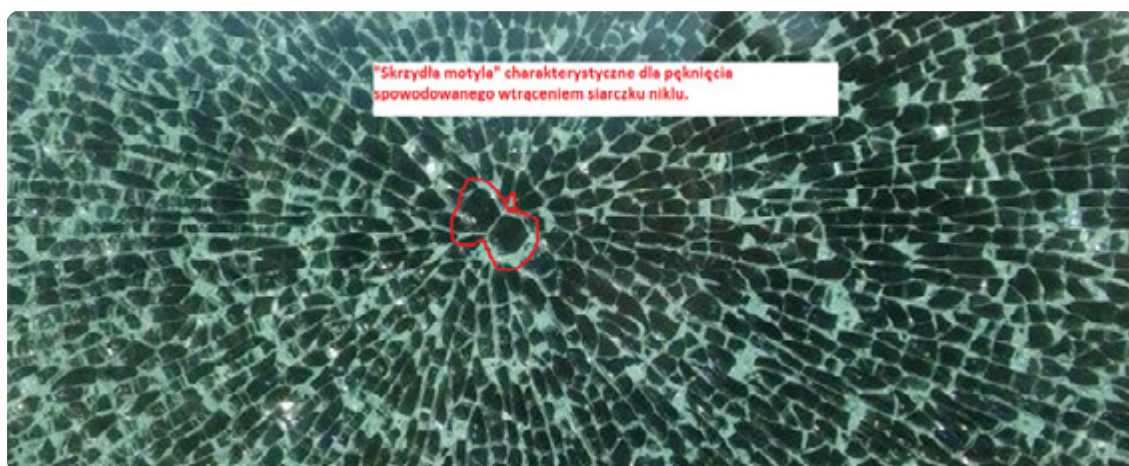

To reduce the risk of such breakage, it is recommended to subject the toughened glass to the additional HST (Heat-Soak-Test) process offered by Glassolutions. We would like to inform you that the toughened glass that is part of the insulating glass units is covered by a guarantee for safety parameters (defragmentation, increased mechanical strength), while spontaneous cracks of the toughened glass are not covered by the warranty.

It should be noted that the HST process is a special process, carried out at the express request of the customer. In other cases, the glass is subject to the standard toughening process.

Condensation of water vapor

The phenomenon of condensation on the outside of the IGU is not a defect of the glazing, as it is caused by the difference in the degree of humidity and weather conditions.

External condensation on the glass is a visible proof of the low heat transfer coefficient U, i.e. high thermal insulation of windows, and it is a natural phenomenon. It can appear on any surface as soon as its temperature drops below the dew point of the surrounding air - especially on flat surfaces such as glass. An example of condensation on windows is on cars in the morning after clear cold night. The same phenomenon can also take place on window panes, when the air coolness in a cloudless sky is not balanced with the heat loss through the window. Modern insulating glass units have such a good thermal insulation (low heat transmittance coefficient U) that this phenomenon may appear in cloudless skies and windless weather at night.



This effect occurs especially on flat surfaces, during the high daily temperature amplitude. It is worth adding that the basic condition for this type of problem is to maintain proper air circulation in the room. This is especially true of rooms where, for obvious reasons, there is the most water vapor, i.e.

kitchens, bathrooms and bedrooms. This problem appears especially where old leaky windows are replaced with new ones, much tighter than the previous ones.

During condensation, patterns may appear on the surface of the glass - which are normally invisible to the naked eye. They result from the water-repellent properties of the glass after



contact with other materials or substances as well as removed labels / stickers. Patterns appearing on the glass - visible during the condensation of water vapor on the glass surfaces do not indicate a defect and have no effect on the performance of the glass in terms of mechanical or chemical-physical.

These traces can be removed by the customer at their own risk with the 3M™ Glass Polishing Compound 60150, however, with too long and intensive cleaning there is a risk of optical distortions.

It should be noted that the presence of condensation on the glass surface from the inside of the building indicates bad ventilation or an incorrectly selected heating system and should be the subject of a heating and ventilation consultation in terms of the possibility of moisture in the building.

Condensation inside the building is mainly caused by high indoor humidity and low outdoor temperature. Kitchens, bathrooms and other rooms with high humidity are particularly susceptible. Under such conditions, condensation appears on the windows at night and persists in the early hours of the morning, reducing visibility through the window due to the refraction of light in the small water droplets. During the day, as the outside air temperature increases, condensation will always disappear. To reduce the visual discomfort that occupants of buildings with energy-efficient windows may experience for the first part of the day, there are some measures to reduce the occurrence of condensation, such as screening * or the use of a self-cleaning coating.

* Shielding - During a cloudless night, the sky temperature can be up to 30 degrees lower than the air temperature. This is because of the heat loss resulting from the radiation of heat through the earth relative to the sky. These losses can be reduced by using various forms of window screening, such as overhanging roofs or external roller shutters / louvers. Heat losses are also lower if there are trees or other adjacent buildings near the windows. These elements reduce the cooling effect of the sky and thus limit the possibility of condensation.

Water condensation at the edges of the glazing unit inside the rooms is caused by the use of metal frames - i.e. aluminum and steel. The use of warm spacers in insulating glass units, eg Swisspacer, eliminates this phenomenon.



To sum up:

1. In rooms. Water condensation on the glass surface from the room side is caused by high humidity in the room.
2. The water is condensing to the outside. The presence of condensed water on the outer surface of the glass is a positive indicator of the thermal insulation of the glass.
3. Water condensation pattern. Patterns formed on the surface of the glass by water / moisture condensation are known as „drip patterns” and are not indicative of a defect of the glass. They are formed due to the presence of microscopic silicone deposits on the glass surface, which decompose over time. Emerging patterns and impressions - e.g. from the suction cups used for the transport and installation of glass panes. Visible only after misting up the glass pane, and invisible in the inspection conditions of the glass compliant with the EN1279 standard (minimum clean and dry surface of the assessed glass), are a natural property of the glazing unit and are not classified as a physical defect of the glass.
4. If the new IG unit is installed close to the old glazing, the glass surfaces in these glazing units will have a different age, so condensation / moisture may form different patterns on them.
5. Water condensation in the space between the panes. The presence of condensed water in the space between the panes indicates that the insulating glass unit has lost its tightness; this is a defect of the IG unit.



The phenomenon of water vapor condensation on the outer surfaces of glass panes is a natural physical phenomenon and in no case indicates a defect, but rather confirms the high quality of insulating glass units.

The European Standard PN EN 1279, in part 1 - Annex C, states that the phenomenon of external condensation is not a defect of the insulating glass unit.

GLASS CRACKS

Cracked glass / external defects / nicks / scratches and chemical defects on the external surface of products that may arise and appear outside the manufacturer's plant - are not subject to warranty and complaints.

Thermal cracks. Cracks due to thermal stress appear when the glass temperature changes suddenly. The risk of thermal cracks increases in installations with high partial shading, where glass is the support element (e.g. posters, furniture), where curtains are used, films are applied, and where heaters or air conditioners are aimed directly at the glass. Thermal cracking may also occur when the glass delivered on the racks is exposed to strong sunlight - such cases are not covered by the warranty.

Composite glass not yet installed in the window frames (panes on a stand) must not be stored in direct sunlight.

ATTENTION!

The glass is secured with straps only for transport. After unloading, loosen the securing straps.

17.1

GLASS CRACKS

Brittleness and thermal expansion are a natural property of glass. Improper storage of glass leading to breakage is not considered a defect.

Glass is a brittle material, and most cracks are caused by one or more interrelated factors such as:

- damage to the edge of the glass (nicks)
- damage to the glass surface (scratches)
- mechanical stress
- thermal stresses
- inclusions in glass
- contact of glass with other materials (e.g. metal)
- vandalism

The strength of glass results from its chemical structure and molecular structure, however, mechanical and thermal loads also have a significant impact on the strength of the glass. Exposing the glass to excessive mechanical and thermal stress may cause it to break.

The thermal stresses that can directly cause the glass to break are usually the result of exposure to sunlight - the temperature inside the chambers can reach temperatures of up to 90 degrees Celsius when exposed to strong sunlight. The key factor here is the temperature gradient, but also the gusts of air, which additionally create a thermal shock. High stresses in the glass are most often caused by intense and at the same time heterogeneous heating of the glass on its surface.

If the temperature distribution in a given material is not homogeneous, thermally induced stresses occur. Regions of the glass heated by sunlight or other heat sources begin to expand, while the currently unheated surfaces are colder and are subjected to tensile stresses. If the tensile strength point is exceeded in this situation, it breaks.

In the case of double glazing units exposed on stands - the greatest thermal shock may be related to the internal panes because they have temperatures of up to 90 degrees inside them - and on the very edges, protruding a few mm, a temperature of 30 degrees (cooling through the external surfaces) may appear in the case of external glass panes in double-chamber panes, as it were, their entire surface is cooled by external air, therefore the risk of thermal shock is much lower.

It is worth noting that glass is very resistant to loads that lead to compressive stresses, but this is not the case for loads that cause tensile stresses. The tensile strength of glass is only about one-tenth of its compressive strength. Therefore, the level of heating of the central glazing area relative to the edge of the glazing unit is important.

Glass is a kind of heat accumulator - in the case of cracks caused by thermal stresses, microcracks appear at the stage of glass heating, while the crack itself (organoleptically visible) often occurs when the glass cools down and shrinks in terms of its thermal expansion, e.g. during cooler temperature at night, or as a result of a change in exposure to sunlight as a result of placing windows under a tent or transporting it from a sunny place to the production hall. Note - thermal stresses also occur in winter - when outside temperatures reach e.g. -10 degrees and in production halls the temperature is +20 degrees.

To illustrate simply - there is a greater probability of thermal stresses that can cause cracks in spring, when the air temperature fluctuates around 20 degrees in strong sunlight, than in the summer months, when the same operation of the sun - the air temperature fluctuates around 35 degrees. The key factor here is the temperature gradient as well as cold air blasts (creating an additional thermal shock). These properties and the causes of glass breakage are discussed broadly in industry literature.

For the production of insulating glass, Glassolutions uses only base glass (float and coating glass) that meets the EN standard, which defines the limit values for stresses in the glass resulting from the production process of this glass.

Minimizing the risk of mechanical fractures.

Eurocode 1991 Euro code 1: Actions on structures - Part 1-1: General actions - Densities, self-weight, imposed loads for buildings defines the so-called Reduction factor. It defines the mechanical strength of the glass depending on whether we have an „original” edge after cutting or a machined edge.:



Tempered glass is always edge worked and it is recommended that annealed and laminated glasses are also edge worked to reduce the risk of mechanical cracks or breakage during transport and installation.

17.2

CRACKS TYPES

THERMAL CRACKS

Characteristic signs of a thermal break:

- The course of the crack at straight angles from the edge into the glass surface
 - The crack is at straight angles to the thickness of the glass
 - The course of a thermal break always follows the path of least resistance.
- Thermal cracks can change direction many times.

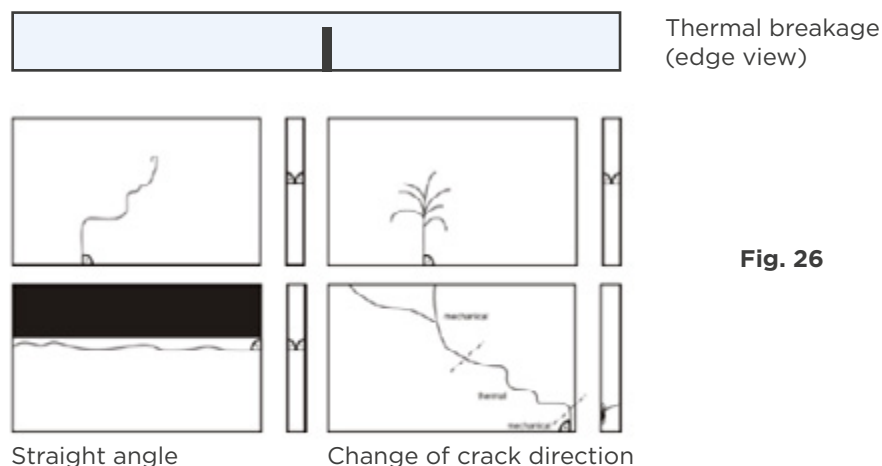

If the temperature distribution in a material is not uniform, it causes thermally induced stresses. Areas of the glass that will be heated by sunlight or other heat sources begin to expand. On the other hand, the currently unheated surfaces are colder and are subjected to tensile stresses. If the tensile strength point is exceeded in this situation, it breaks.

Therefore, the level of heating of the central glazing area relative to the edge of the glazing unit is important. Due to the way in which the glass is mounted, i.e. embedded in the window frame, the edges of the unit always remain shaded, so their temperature is lower than the central part of the glass. This results in the appearance of tensile stresses in the peripheral part of the pane covered with the frame.

The factors that generate thermal cracks are listed below:

- glazing frames in direct contact with concrete or other materials that may contribute to lowering the temperature at the edges of the glass,
- the use of internal shading objects, such as curtains, blinds, roller blinds, flowers, etc. - their installation increases the level of thermal stress and should be approved by an appropriate thermal analysis,
- placing a heat-absorbing foil on the installed glazing,
- directing the air from the heating or air conditioning system towards the glazing.

In addition, the phenomenon of cracking glass due to thermal stress may intensify in buildings that are not heated, e.g. during construction.

In the case of thermal cracks in triple glazing, due to the structure of the insulating glass unit - the highest temperature is achieved by the internal pane and it breaks most often. The outer panes are, in a way, air-cooled. In the case of the internal glass - when the center of the glass is 90 degrees and the edge of the glass, a small part of which has access to the „environment” only 20 degrees - thermal stresses - resulting from thermal expansion of the glass cause it to crack.

Because glass is a kind of heat accumulator - in the case of cracks caused by thermal stresses - microcracks appear at the stage of heating the glass, while the crack itself (organoleptically visible) occurs when the glass cools down and shrinks in terms of its thermal expansion - which may explain why the cracks they reveal themselves after being transported to the production hall

MECHANICAL BREAKAGE

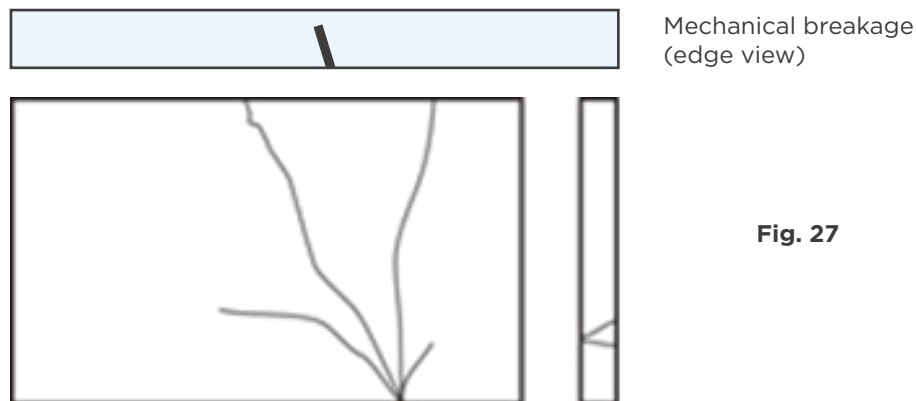

Fig. 27

Signs specific to mechanical fracture (e.g. caused by bending stress)

- the fracture from the edge into the surface of the glazing may be, but need not be, at straight angles
- the crack through the thickness of the glass is not at straight angles
- the crack caused by bending the glass does not always run along the path of least resistance.

Below are examples of typical mechanical damage to glass:

Cracks during assembly may arise as a result:

- wrong thickness of spacers
- contact of glass with other materials (e.g. metal)
- tightening the glass fasteners with too much force
- too tight fit of the glazing bead
- damage caused by impact

Mechanical cracks formed on the installed panes may arise as a result of:

- too large difference in air pressure, temperature and height between the place of production and the place of installation of the glass
- poorly selected glass structure with too high wind load
- incorrect dimensions of the glass in relation to the frame
- missing or incorrect spacers
- glass hits (e.g. stone, ball, hammer.)

In accordance with the General Terms of Sale of Glassolutions:

Cracked glass / external defects / nicks / scratches and chemical defects on the external surface of products that may arise and appear outside the manufacturer's plant - are not subject to warranty and complaints.

The Seller shall not be liable for any cracks or other external physical or chemical damage to the goods, arising or found upon receipt by the Buyer. The Seller may consider such a case as a justified complaint only if the Buyer indisputably proves that the claimed defect arose for reasons for which the Seller is responsible.

CHARACTERISTIC APPEARANCE OF CRACKED GLASS:

Fig. 28 THERMAL BREAKAGE

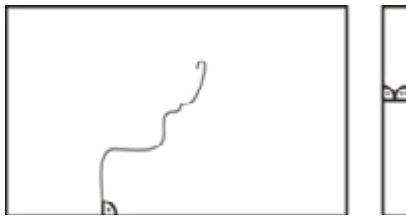

Rys. 29 MECHANICAL BREAKAGE



Fig. 30 BREAKS CAUSED BY ATMOSPHERIC FACTORS
(e.g. wind + mismatched glass or absence of pressure compensation)

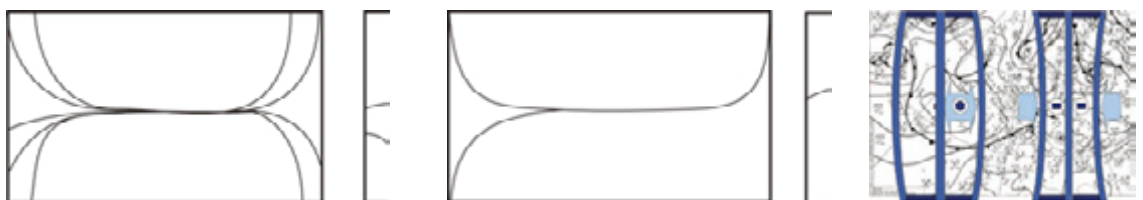

Fig. 31 GLASS DEFECTS
(impact on the edge)



Rys. 32 TRANSPORT BREAKAGE

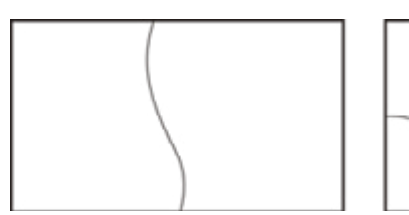

Fig. 33 GLAZING METHOD**Fig. 34** DIVIDERS + ATMOSPHERIC CONDITION**Literature:**

„Ratunku! Pękła mi szyba. Co robić?” część 1, 19/10/2009, portal oknotest.pl, http://oknotest.pl/szyby-i-szklo/ratunku_pekla_mi_szyba_cz1

„Ratunku! Pękła mi szyba. Co robić?” część 2, 19/10/2009, portal oknotest.pl, http://oknotest.pl/szyby-i-szklo/ratunku_pekla_mi_szyba_cz2

Daniel Giaquinto, Franz-Joerg Dall, „Rodzaje i przyczyny uszkodzeń szkła” część 2, 10/02/2013, Glaswelt 5/2012, publikacja na stronie Świat Szkła, <http://www.swiat-szkla.pl/aktualnoci/236-wydanie-012013/6973-rodzaje-i-przyczyny-uszkodze-szka-cz-2.html>

Optical phenomena

The physical properties of the glass and the structure of the insulating glass unit determine some specific properties of insulating glass and single glass, which are not defects, are not subject to complaint and are not covered by the warranty. This is described in detail in the standard EN 1279 Annex C - and the standards harmonized with EN 1279, such as EN 12150/14449/356 etc.

According to the criteria included in the standards, glass should be inspected under the following conditions:

1. Glass placed vertically
2. Parallel to the dull gray screen,
3. In bright, diffused daylight
4. No additional light source
5. The observer should be 2m from the glass, observing it perpendicularly

When assessing the glass according to the above criteria, the optical phenomenon that causes your objections will not be visible, and thus cannot be the basis for a complaint.

Image reflection

Since insulating glass units consist of more than one glass pane, the viewer may notice multiple reflections. This effect will be stronger in triple glazing. It is not a defect of the glass.

Deformation in reflection

The hermetically sealed space between the panes contains a fixed volume of air / gas, dictated by the temperature and atmospheric pressure values prevailing at the time of joining.

After the installation of the glass, changes in the outside temperature and pressure will result in an increase or decrease in the volume of air / gas in the space between the glass panes, which in turn will cause the glass pane to bend visible in the form of a distorted reflection image. This distortion indicates that the glazing has been properly sealed and is not a sign of a glass defect. The phenomenon is described in the EN1279-1: G.5 standard

When insulating glass units are installed above 700 m above sea level or if there is a relative height difference between the production site (Glassolutions plant) and the installation site greater than 500 m, it is recommended to perform pressure compensation. This will reduce the concavity / convex effect of the insulating glass units and reduce the risk of glass breakage.

Toughened glass may show some visual and color distortions, more emphasized in the reflection of images from double glazing units. Such surface colors and patterns do not indicate a change in the physical properties of the pane and are not indicative of a defect.

The refraction of light on the glass may cause slight temporary rainbow effects. They appear due to the parallel alignment of high-quality flat glass panes to each other, as well as due to the different orientation of the toughened glass.

The glazing technology is constantly evolving, so the newly produced glass panes installed next to the older ones do not have to match them perfectly. This situation is not due to a defect in the glass.

The low-E coating of the glass can cause temporary visual effects. Under certain lighting conditions, this coating may appear as a transparent film or may cause a hazy effect on the glass surface. When light, colored objects such as curtains are placed adjacent to the glass, they may appear slightly darker than they really are. Variations in the construction of adjacent glazing units can also produce visual effects that are acceptable.

When using laminated glass, the so-called Moire effect, which is not a disadvantage of such insulating glass units.

Other visual phenomena appearing on the panes are described in Annex G of EN1279-1

In case the new IG unit is installed close to the old glass, the glass surfaces in these glass panes will have a different age, so condensation / moisture may create different patterns on them.

Roll imprint

The process of thermal strengthening of glass involves placing the heated glass on rolls in the furnace. This can result in small imprints on the glass surface. These may be clearer with thicker types of glass.

Roller wave

(only for toughened glass) The curing rollers may also cause slight unevenness to the glass surface. According to the EN 572 standard, the maximum deformation (wave) can be 0.3 mm / 300 mm.

Haze

Under certain lighting conditions and at certain angles, certain coatings or laminated products can cause a phenomenon called haze (a blurred, dusty appearance). It is not a defect of glass.

Anisotropy

Insulating glass units with thermally strengthened and toughened glass panes can be characterized by the occurrence of the phenomenon called anisotropy - the phenomenon is described by the standards EN12150-1, EN1836-1.



Color variations

Color variations that may occur between adjacent insulating glass units of the same construction are acceptable as long as they meet the ISO 11479-2 criteria for measuring and assessing the color of coated glass used in building facades. Windows with different coatings / reverse-placed glass / laminated / toughened glass / float / different sizes of glass / different colors of walls in rooms etc. When placed next to each other, they can give the effect of color differences because they are different products. Most of the float glass used for the construction of insulating glass, eg 4/16/4, are based on the so-called Planiclear or other competitive equivalent. It is a greenish glass. If you want to order completely white and transparent glass - you can order the so-called glass. Diamant, i.e. low iron glass.

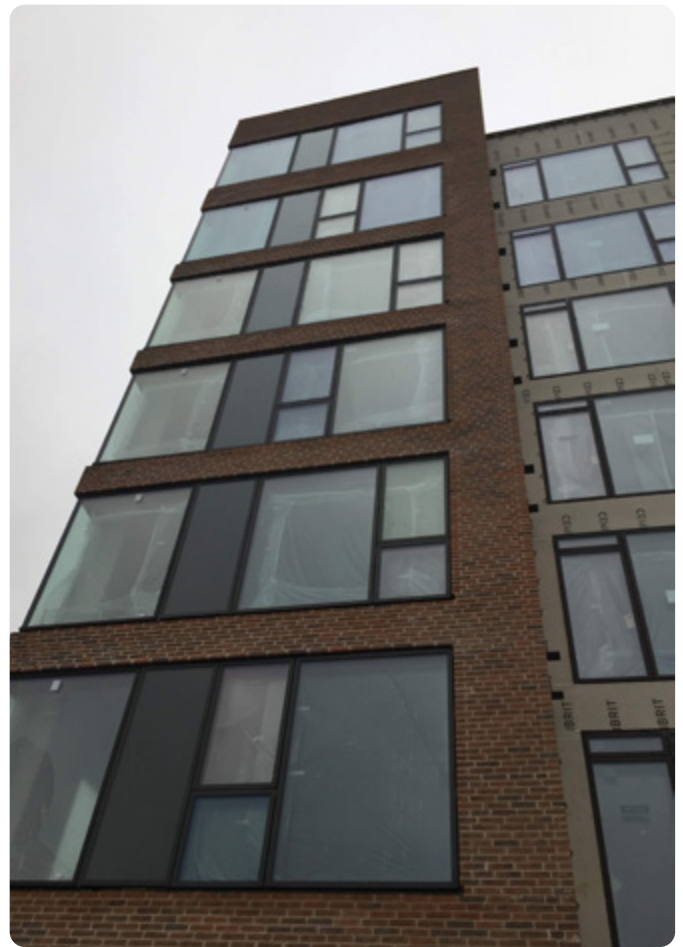

It should also be remembered that over time and for unintentional reasons, the outer surfaces of the insulating glass units may be affected by the weather, which affects their appearance.

Newton's rings

Optical phenomenon in insulating glass consisting in the visualization of colored rings in the shape of rings. Rings - interference fringes - are formed when light passes through thin layers near the contact of a convex and flat surface, separated by a substance with a refractive index other than the layers in contact. This optical effect occurs in insulating glass units when the two panes touch or almost touch in the center of an IGU filled with gas [substance]. The optical effect is a series of concentric colored rings in the center of the glass, which is the point of contact or close contact between the two panes. The rings are approximately circular or elliptical in shape. The interference occurs inside a thin layer of gas that fills the glass. Newton's rings appear in glass of improper structure, i.e. with too large surfaces and their insufficient thickness and with the simultaneous use of a frame with a small width. Due to the low temperatures, the panes come together in the center and form concave surfaces.

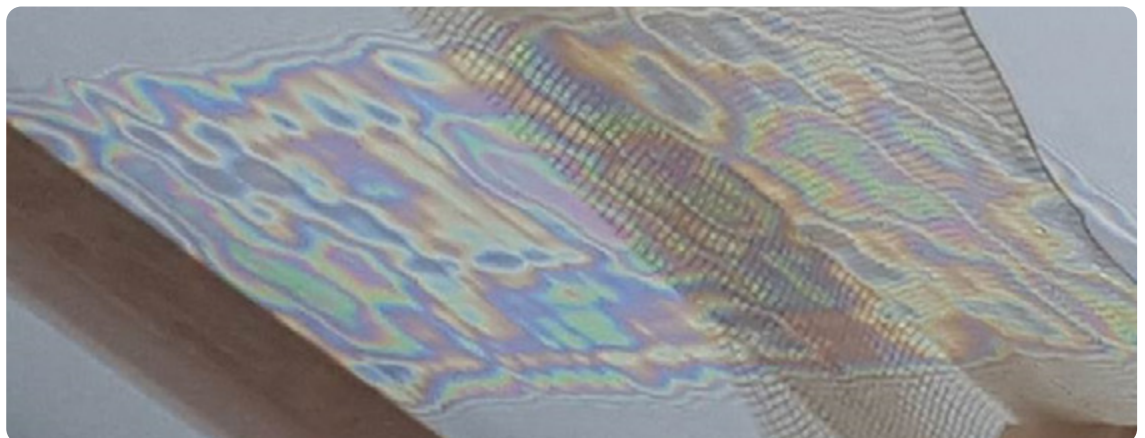

Brewster stripes

They can appear in a set where the two panes are almost the same thickness. (The difference in thickness between the two panes must be very small and approximately the same as the average wavelength of visible light, i.e. 0.0005 mm). Brewster stripes are observed more often in sets made of float glass than of drawn glass, because float glass, is very flat and shows relatively small differences in thickness. A necessary condition for the appearance of the Brewster stripes is the presence of two panes of almost the same thickness in the double glazing, their difference in thickness should be approximately 0.00035 to 0.0007.

Silvery coating on the glass

Occasional defect resulting from improper joining of glass panes with the low-emission layer of metal oxides outside the glazing unit.

Concave and convexity of the glass

The glazing unit closed with a seal contains a specific volume of gas in the space between the panes. The volume of the gas is determined by the barometric air pressure, the absolute altitude and the air temperature at the time and place of production. When insulating glass is installed at different heights, concave and convex bends of the individual panes inevitably arise with changes in temperature and deviations in atmospheric pressure and thus optical distortions. The occurrence of this phenomenon proves that the panes are well-made - they are simply tight. This phenomenon is often more pronounced in unfinished buildings where the building is still unheated.

Example:



For the installation height of the glass unit above 700 meters above sea level - it is necessary to inform the Manufacturer about the installation height in order to check the necessity to compensate the pressure in the unit or the necessity to change the structure. Cracks due to concavity and convexity as well as unsealing of the insulating glass unit installed above 700 meters above sea level, which was not subject to compensation, are not covered by the warranty. The physical properties of the glass and the structure of the insulating glass determine some specific properties of insulating glass and single glass, which are not Defects, are not subject to complaint and are not covered by the warranty - these phenomena are described in the General Warranty Conditions and in related documents.

Details of this phenomenon are described in the PN-EN 1279-1 Standard - Annex C - Optical and Visual Quality of Glazing

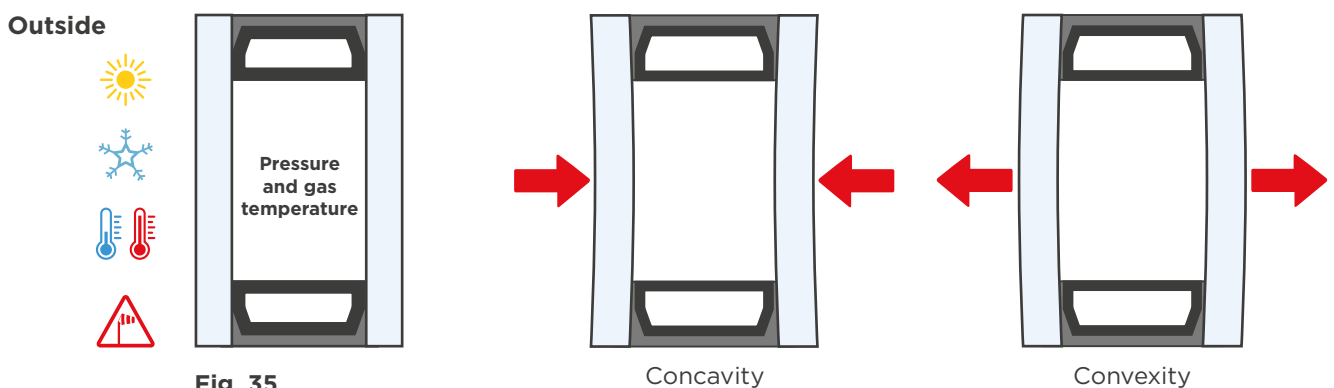

Fig. 35

The limit above 700 meters above sea level - with the necessity to perform pressure compensation or a change of construction - results from the fact - the lower fracture resistance of IGUs to „stretching - convex” than „compression - concavity”. On the other hand, pressure compensation - does not eliminate this phenomenon (concavities and convexities).

If the glazing is installed at an altitude of less than 700 m above sea level - there is no risk of cracks, but the phenomenon of concavity may occur. The concavity / convexity phenomenon, in addition to atmospheric conditions - pressure and temperature, is also influenced by the tolerance of the window frame dimensions in relation to the glass insert, as well as the pressure of the building structure on the frame - this is described in detail in PN-EN1279-5 - Annex C - Installation of Insulating Glass Units as well as in prEN ISO14439 / prEN12449

Concavity and convexity of IG units are a natural phenomenon and are not covered by the warranty.

19

Thermal analyzes

In the case of window and facade applications, as well as on roofs, floors - wherever we deal with the operation of sunlight. The customer is required to perform thermal analyzes, e.g. in the Glazing Decision program.

The temperature inside the laminated glass cannot exceed 65°C - because glass above this temperature loses its mechanical properties and adhesions.

20

Toughening glass with a low-emission coating in the middle position

Stained / colored glass such as antelio, stopsol, parsol, planibel, solar and solar coatings, e.g. SKN and XTREME in triple glazing used as middle panes, must be toughened due to the risk of thermal cracks appearing.

Colored ornamental glass in triple glazing used as central panes must absolutely be toughened due to the risk, bordering on certainty, of the appearance of thermal cracks.

We also recommend toughening colorless ornamental glass in triple glazing used as central panes.

For low-emission coating glasses such as XN / ECLAZ: when using a black or dark frame, the temperature in the center of the glass can be up to 90 degrees and the increasingly popular window blinds and pleated blinds, in which the thermal stress gradient is double. We recommend toughening all the coated glasses when they are on the middle pane, i.e. the coating is in position 3 or 4.

In the event of deviation from this recommendation, you must be aware of the risk of thermal cracks due to the lack of toughening of this glass.

Thermal cracks appear most often during use by end users.

Bioclean

Bioclean is a self-cleaning glass that requires regular exposure to rain on the surfaces. The use of Bioclean glass under canopies, in window recesses, may mean that the basic function of this glass will not be fulfilled due to the lack of rain.

The phenomenon shown in the photos may be caused by improper maintenance of SGG BIOCLEAN self-cleaning glass. In order for the glass to perform a self-cleaning function, follow the (manufacturer's) instructions available on the website glassolutions.pl/pl/warunki.

As a reminder, here are the cleaning recommendations for Bioclean glass:

- If the SGG BIOCLEAN label is still on the glass, carefully remove it. Do not use sharp tools that can scratch the coating or the glass (razor blade, putty knife, abrasives).
- The first cleaning of the glass should take place not earlier than one week after installing the window. Wash the outer pane with plenty of water to activate it
- Self-cleaning function: within a week after installation and the first wash, the self-cleaning property of SGG BIOCLEAN becomes gradually active under the influence of UV rays.
- Routine maintenance: A feature of SGG BIOCLEAN is that it does not get dirty with less dirt than ordinary glass. The frequency of washing depends on the degree of exposure to the sun and rain as well as the level of atmospheric pollution.
- Cleaning tools: rubber windscreen cleaner in good condition, clean and silicone-free; clean and soft cloth, sponge clean and non-abrasive.
- Cleaning agents: clear water and ordinary neutral glass cleaners. As with any glass, the water should be low in calcium. If necessary, use softened or demineralized water.
- Do not use: cleaning or processing agents containing silicones or abrasive particles; maintenance agents for materials other than glass (aluminum, wood, etc.); chemicals: baking soda, javel water, lye; abrasive tools: sponges and abrasive rags, steel wool, razor blades, knives.

It is also worth noting that thanks to the hydrophilic effect and photocatalytic coating applied to the SGG BIOCLEAN glass surface, keeping the windows clean is easier and the need to wash the glass is reduced, but the user is not (completely) exempt from the obligation to clean the glass. SGG BIOCLEAN is not a glass that does not require any maintenance. If the window is covered with a roof / recess and rainfall does not reach the glass surface - the coating may not be fully active.

ATTENTION

Incorrect maintenance of the product may irreversibly damage the self-cleaning coating.

Glass selection

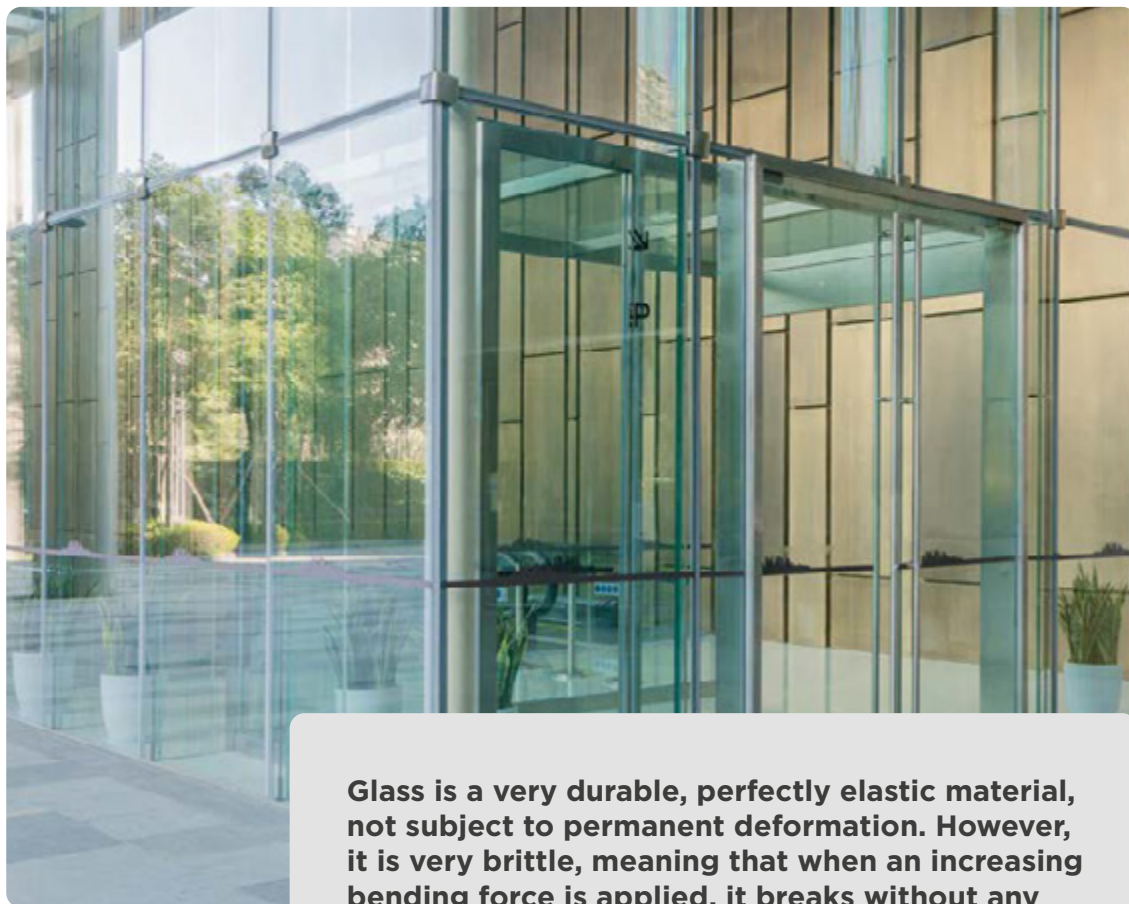

Glass is a very durable, perfectly elastic material, not subject to permanent deformation. However, it is very brittle, meaning that when an increasing bending force is applied, it breaks without any previous symptoms.

It should also be remembered that the annealed float glass has sharp edges when it is broken, which may be dangerous to users if used incorrectly.

In Europe, in the case of construction glass, the basis for selection is always Eurocode 1-1991, which is a set of European standards defining the principles of designing and executing building structures and methods of verifying the characteristics of construction products of structural significance, in force in the Member States of the European Union on the basis of a harmonization document. Eurocodes have the so-called national annex - national annexes that define the windmaps and keys for calculations for urban, rural and coastal areas.

Failure to meet the requirements of Eurocode 1 in the case of glazing selection is tantamount to failure to comply with the construction law in Poland and Europe.

THE IMPORTANCE OF THE SELECTION OF GLASSES

Wrong selection of glass can lead not only to accidents, but also to glass cracking already at the stage of transporting insulating glass units, window production and transport, installation, and during use. Often, window users report „squeaking windows in high winds”. It is caused by exceeding the maximum deformation or stress of the glass panes. In Poland, the selection of glazing for a given investment is the responsibility of the architect / designer / constructor of a given facility. At the design stage, they should take into account, inter alia, structure loads and location affecting, for example, wind load, exposure to high temperatures, and the size of the glazing. In addition, the selection of glass is also determined by its use and function in a given facility, The purpose and use of the building itself - for example, whether the building is intended for resi-

The order of criteria for selecting glass for windows

The choice of glass for windows should be made according to the indicators in the following order:



dential use (single or multi-family) or is a public building.

On the other hand, in the case of ready-made single-family house projects, the architect does not define the type of glass that should be used - here the responsibility falls directly on window dealers and window producers.

Using the appropriate glazing statics software, e.g. MEPLA or GLASGLOBAL, knowing the dimensions of the insulating glass units and the place of installation of the windows, you can quickly calculate the statics of the insulating glass so that it meets the Eurocode requirements. The statics of insulating glass already at the offer stage.

In addition to the Eurocode, which is always the basis, depending on the country, there may be additional requirements in legal or industry standards. Standards define this in Germany DIN18008 / TRAV / TRLV, in Belgium standard NBN23-002, in the Netherlands standard NEN6702, and in England BS 6180. In the case of Poland, it is most often made on the basis of DIN18008 or guidelines of the Building Research Institute (series of Instructions, Guidelines, Guides - edition No. 488 / 2013 „Structural elements made of building glass”).

BARRIER GLASS AND ANTI-CUT GLASS

It is very popular to define safety glass with classes P2A, P4A etc. This approach is partially wrong, as these classes do not directly define the protection of users in contact with the glass. The P1A-P8A classes, related to the EN356 standard (ball drop test), mean glass with increased burglary resistance, not safety glass. When talking about protecting users from falling out, we should use glass with the class 1B1 / 2B2 / 3B3, i.e. the EN12600 standard - tire pendulum test. 1B1 class glass can act as a barrier to protect users against falling out. Such glass should be used wherever the height from the floor to the glass is less than 80 cm, and where the fall height when the glass is broken is greater than 150 cm (e.g. 1st floor). Attention!!! Toughened glass and glass 33.1 do not have the 1B1 class and cannot constitute a barrier protecting against falling out. In the case of windows where the height from the floor to the glass is less than 80 cm and there is no risk of falling from a height (ground floor / terrace), we are dealing with an anti-injury barrier. This is especially important when children are present or wherever we have panoramic glazing that the user may not see.

The anti-cut barrier may be glass 33.1 applied from the user's side. Example: In the case of a double-chamber glazing, where the user has access only from the inside of the building, we use glass 33.1 from the user's side (e.g. 4/16/4/16 / 33.1). If the same glass is used, where the user has access both from inside the building and from, for example, the terrace, the structure of the glass must be symmetrical (e.g. 33.1 / 16/4/16 / 33.1). When the laminated glass is used symmetrically - the central pane may be annealed float glass. In the case of an anti-cutting barrier and the desire to use toughened glass instead of laminated glass, all components of the insulating glass must be toughened, otherwise such glass will not fulfill its function at the moment of breaking (example structure: 4ESG / 16 / 4ESG / 16 / 4ESG). A common requirement (e.g. in the UK) is to place an appropriate logo on all panes of laminated and tempered glass. Finally, we would like to emphasize once again that apart from the price, acoustics and insulation, there are many other parameters of glass that should be borne in mind when selling or buying a window.

IN POLAND, THE SELECTION OF GLAZING FOR A GIVEN INVESTMENT LIES ON THE SIDE OF THE ARCHITECT / DESIGNER / CONSTRUCTOR OF THE FACILITY. AT THE PROJECT STAGE, THEY SHOULD BE TAKEN INTO ACCOUNT, STRUCTURAL LOADS AND LOCATION WHICH AFFECT THE WIND LOAD, EXPOSURE TO HIGH TEMPERATURES, GLAZING.

23

Window glazing

Any modifications of insulating glass units, including their wrapping with sun protection films, Venetian films, anti-burglary films, etc. - without prior agreement and supervision by Saint-Gobain Polska already at the glazing production stage - constitute a modification of the construction product. Such modifications by third parties may cause:

- changing the parameters declared in the Declaration of Performance
- high risk of thermal cracks
- risk of unsealed windows
- loss of mechanical properties
- optical distortions
- tarnishing the glass over time
- deterioration of the insulating conditions of insulating glass units.

The result of these modifications:

- a) Loss of guarantee for insulating glass units by Saint-Gobain Polska
- b) Loss of the CE marking for the construction product which is insulating glass.

In the light of legal liability and European standards EN1279 - the ordering party and a third party making such a modification without agreeing with the manufacturer takes responsibility for the use of a construction product without CE marking.

24

VSG laminated glass delamination

SEALANT COMPATIBILITY

Please be assured that we regularly test our products to maintain the highest standards. Primary and secondary sealants used in Glassolutions (Butyl and Thiokol) are regularly tested in accordance with EN 1279, and laminated glass in accordance with EN14449 - this is confirmed by external and internal tests, as well as numerous certification audits.

The silicones and adhesives available on the market are not always compatible with the EN 1279 and EN1449 sealants that are used by Glassolutions. In addition, their chemical composition often changes over time, which means that there is no permanent list of compatible products on the market.

DELAMINATION OF LAMINATED GLASS

The delamination of laminated glass or laminated safety glass is widely described in the scientific literature <https://www.sciencedirect.com/science/article/pii/S0734743X16303049>. There are several causes of delamination of laminated glass such as excessive moisture, incompatibility (e.g. with silicones or fixing elements such as leveling blocks), mismatch or poor glass processing, assembly quality, excessive load on laminated glass.

EXCESSIVE MOISTURE

PVB is hygroscopic and absorbs moisture. If the panes are exposed to excessive moisture at the edge of the interlayer, the adhesion of the PVB film to the glass is limited and delamination may occur. This is often caused by insufficient mounting to allow moisture to accumulate and the provision of drainage is forgotten. The edge of the interlayer must be able to „breathe“.

GLASS DEFLECTION

Heat-treated glass (toughened or heat-strengthened) shows deformation in the glass caused by rollers during the toughening manufacturing process. This distortion is commonly known as roller ripple or edge drooping. If the distortion in the glass layers is not „fit” from top to top and bottom to bottom, there may be stresses on the interlayer, especially at the edges. Delamination can occur if the interlayer is unable to withstand the stresses caused by the glass layers. This point is 100% controlled by Glassolutions and verified by notified bodies.

WIND LOADS / CONSTRUCTION LOADS

The delamination process of laminated glass can be caused by the absorption of a significant amount of energy in windows containing this type of glass. During its life cycle, insulating glass units are exposed to various types of mechanical stresses:

- weight used,
- wind pressure on the facade,
- snow pressure on the roof,
- own weight,
- sunlight (especially in the case of coated glass and insulating glass units with VSG glass) may increase the pressure and temperature of the gas inside the IG unit.

In a situation where the glass used causes too much deflection and tension, stressing (too thin glass) due to gust/wind or structural load – the phenomenon of “PVB foil shearing” may occur, which may cause delamination of the glass.

INSTALLATION QUALITY

If not completely removed, cleaners and primers used to prepare laminated glass prior to glazing with structural silicone may destroy the PVB film layer, thus promoting delamination of the glass.

CONFORMITY OF MOUNTING MATERIALS

It is important to ensure that the correct type of structural and assembly silicone is used to ensure compatibility with the interlayer PVB film used; wrong selection can lead to delamination. The customer is responsible for this point and is described in our TERMS OF SALE AND WARRANTY.

PVB film suppliers carry out free structural and assembly silicone analyzes. In such tables, you can check whether delamination or Plateau will occur, as well as the maximum depth of the delamination phenomenon. Structural and assembly silicones in which there is no Plateau effect and the delamination depth for laminated glass is a maximum of 0.0 mm are considered safe. For structural and assembly silicones that have not been tested by the PVB film supplier, it is impossible to predict how they will behave after assembly .

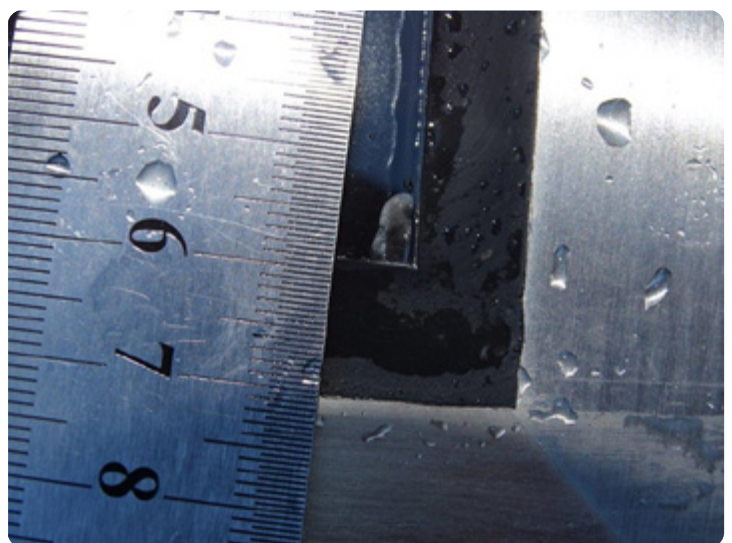

Table 35

Evaluation Program Results

Interlayer Type: Saflex® Structural (DG) PVB interlayer
 Exposure Type: UV/Condensation; UV 313 Bulbs;
 Exposure Cycle: 16 hours of UV (no condensation) at 66°C, 8 hours of condensation (no UV light) at 60°C.
 Total Laminate Edge Exposed (mm): 580

Interlayer Thickness: 0.76 mm (0.030 in)
 Total Exposure (Hours): 3500

Table 1: Summary Table of Compatibility Results

Sealant	Manufacturer	Percent of Edge Affected (%)	Area Affected (mm ²)*	Delamination Plateau	Average Depth Total (mm)	Maximum Depth for Laminate (mm)	1	2	3	4	5	6	7	8	9	10	11	12
Arboil LM	Arbo	67	389	Yes	1.0	3.0												
Simson MSR CA	Bostik	0	0	**	0.0	0.0												
Simson MSR CA SSKF	Bostik	0	0	**	0.0	0.0												
DC 3362	DowSil	70	1218	No	3.0	5.0												
DC 3362HD	DowSil	61	941	Yes	2.0	2.0												
DC 3363	DowSil	71	827	Yes	2.0	3.0												
DC 791	DowSil	64	372	**	1.0	3.0												
DC 795	DowSil	47	546	**	2.0	3.0												
DC 895	DowSil	38	220	Yes	1.0	2.0												
DC 990	DowSil	67	369	**	1.0	2.0												
DC 995	DowSil	48	277	**	1.0	3.0												
PrimerP w/ DC 999a	DowSil	0	0	Yes	0.0	0.0												
EGO300	EGO	15	89	No	1.0	2.0												
EGO333	EGO	28	325	Yes	2.0	4.0												
EGO351	EGO	53	687	Yes	3.0	5.0												
EGO460	EGO	61	709	Yes	2.0	4.0												
Thiover F1	Fenzi	0	0	**	0.0	0.0												
GD 116	Kommerling	0	0	**	0.0	0.0												
GD 116NA	Kommerling	0	0	**	0.0	0.0												
GD 677	Kommerling	0	0	**	0.0	0.0												
SCS 2000 (Silpruf)	Momentive	68	784	**	2.0	2.0												
SCS 2803	Momentive	68	789	Yes	2.0	3.0												
SCS2350	Momentive	69	398	**	1.0	3.0												
SSG 4000AC (Ultraglaz)	Momentive	72	418	**	1.0	2.0												
SSG 4600B	Momentive	93	1079	Yes	2.0	3.0												
N Silikon	Nordsil	61	710	**	2.0	4.0												
DRY SEAL™ MP	Repair Care	0	0		0.0	0.0												
Sikasil IG 25	Sika	47	273	Yes	1.0	3.0												
Sikasil IG 25HM	Sika	12	68	Yes	1.0	2.0												
Sikasil SG 500	Sika	52	299	Yes	1.0	3.0												
JS 442	Tremco	0	0	**	0.0	0.0												
JS 562	Tremco	1	6	Yes	1.0	2.0												
Proglaze HM	Tremco	36	211	**	1.0	3.0												
Proglaze II	Tremco	43	251	Yes	1.0	2.0												
Notes:		Average depth			Maximum depth		Average and Maximum depth the same											
		** = trend data not available			*MAS = manufacturer applied sealant													

Applications Technical Documentation (ATD)
 730 Worcester Street | Springfield, MA 01151
glazing@eastman.com | www.saflex.com | www.vanceva.com
 ami and sealant compatibility - saflex structural (dg)_092320.doc
 Page 3 of 4



Delamination can also arise from fixed mounting elements such as leveling pads

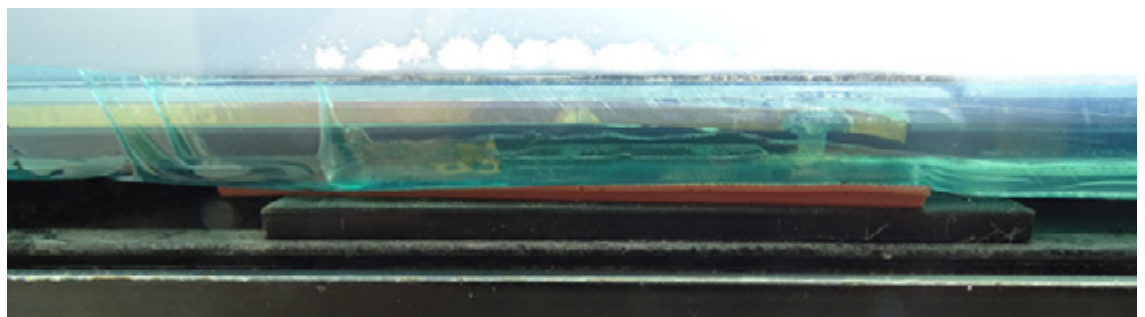

Enameled panes by screen printing

The guidelines refer to the visual assessment of the quality of full or partial coverage of the glass surface with ceramic enamel by silk-screen printing, which are produced as toughened glass, thermally strengthened or with additional heat treatment (Heat-Soak Test) by applying and burning a color.

There is a wide range of colors and patterns that can be obtained with this method.

To assess the suitability of the product, it is required to inform the manufacturer of the final use of the product at the time of ordering. This applies the following points:

- internal or external use,
- use in construction or decorative,
- HST requirements (applications on facades),
- use in clearly visible and directly lit places (visibility from two sides, e.g. partition walls, doors, etc.),
- quality of the edges and their visibility (in the case of unprotected edges, they must be ground or polished),
- further processing of individual panes for bonding or lamination,
- definition of the design (providing the necessary information in the event of creating an individual design).

Where silk-screened or fully printed glass is to be assembled or laminated in succession, each glass pane in the set must be considered separately.

The glass surface is covered with paint using the screen printing method. Ceramic enamel used for screen printing during toughening the glass panes blends into their surface creating a durable coating. In the case of screen printing covering more than 50% of the glass surface, we refer to enamelled glass. Screen printing can also be applied only to the part of the glass defined by any pattern, creating a decorative element.

The color of the base glass always influences the color seen. The enamel side must always be on the side that is not influenced by the weather (face 2 or later). Depending on the production process and the color of the enamel, glass is distinguished by a greater or lesser light transmission and therefore is not opaque. Light colors always have a greater light transmission than dark colors.

In the event of greater differences in illumination or high light intensity (daylight) between the front and the back side of the viewed glass, optical light - dark shadows (especially visible from the side with lower light intensity) may appear. This is directly related to production, it relates to the thickness of the enamel coating and cannot be prevented. This should be taken into account when it is planned that both sides of the glass will be visible.

Enamelled glass is screen-printed and is characterized by the following parameters compared to other methods of applying paint to glass: the thinnest coating; the highest light transmittance the best color uniformity, although micro-holes, shadows and streaks cannot be eliminated. Whenever ordering enamelled glass, it is recommended to view and accept the sample first. In the event that the glass is visible from two sides, we recommend viewing and accepting a sample made in a 1: 1 scale, where the permissible defects will be agreed with the Technology Department. Exceptions are only possible for internal use and consultation with the manufacturer. For applications in visible areas (visible from two sides) always consult the manufacturer as enamelled glass is generally not recommended for applications with an illuminated back side. Differences and details not included in the description below are the result of the manufacturing process and are acceptable.

25.1

PRODUCTION POSSIBILITIES

The production possibilities of making enamelled panes by screen printing are presented in the form of a table - Tab. 1.1. Figure 1.1 shows the scheme of applying enamel by screen printing.

Table 36 Printed glass - possibilities

Printed glass		
	Standard	Complex
Glass thickness	4 - 12 [mm]	15 - 19 [mm]
Min. size	200 x 300 [mm]	100 x 100 [mm]
Max. size	1225 x 2800 [mm]	2130 x 3800 [mm]
Max weight	100 [kg]	400 [kg]

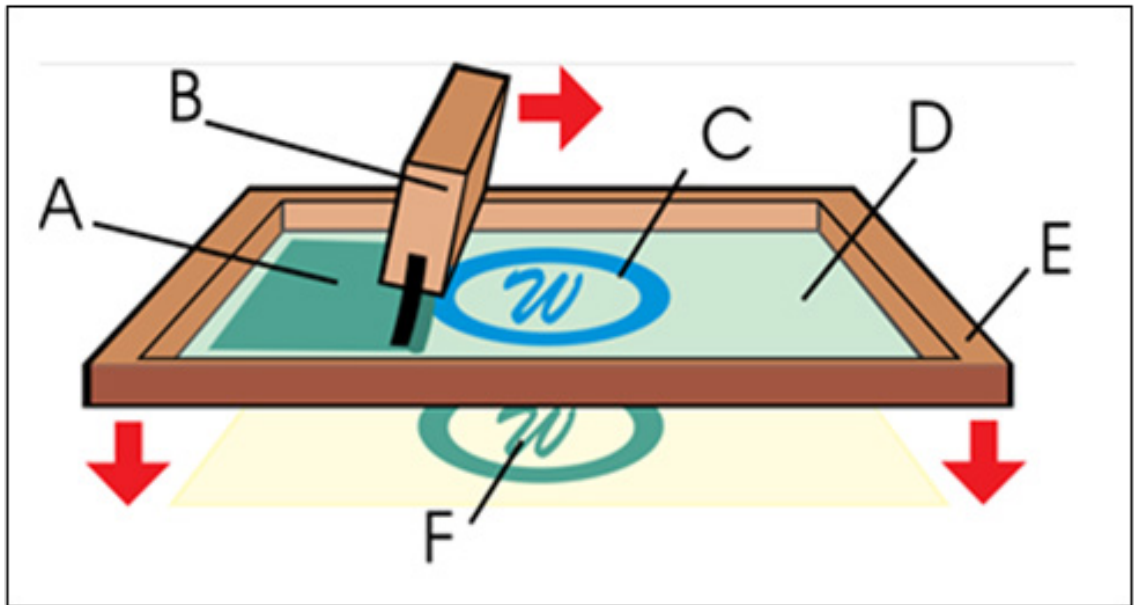
Rys. 36 Screen printing paint application

- A. paint,
- B. doctor blade,
- C. exposed part of the mesh permeable to paint,
- D. part of the mesh impervious to paint,
- E. sieve frame,
- F. reflected pattern.

25.2

DESCRIPTION OF THE TECHNOLOGICAL PROCESSO

The enamel is applied to the glass surface on a horizontal screen printing table with the use of a screen. The thickness of the applied layer depends on the screen used and is relatively thinner than in the roller method. Please note that objects placed directly on the enamelled surface (sealing, glued plates, insulation, handles etc.) may be visible through the glass.

For this method, in applications where the glass is visible from both sides, the supplier must be contacted. Depending on the enamel selected, characteristic of this production method are delicate stripes both in the longitudinal and transverse direction, as well as individual „slightly blurred stains.“.

In screen printing, the edges usually remain clean. There may be a slight „thickening“ of the enamel layer at the edge, therefore the exposed edges must be specified in the order to meet the relevant application requirements. After application, the ceramic enamel is fired in the process of toughening or thermal strengthening of the glass. The strength values of enamelled toughened or heat strengthened glass are lower than for toughened or heat strengthened glass without enamel.

25.3**25.3 VISUAL ASSESSMENT OF THE PRINT**

When painting glass by screen printing, the paint is applied to the glass surface through a fine sieve using a doctor blade - Fig. 36 The thickness of the paint layer is so thin that it may show some transparency (depending on the paint used). The visual quality of silk-screened and enameled glass is assessed from a distance of 3 m perpendicular to the glass surface in normal daylight without the possibility of backlighting. The unpainted side of the glass (for opaque applications) or both sides of the glass for translucent applications are viewed. Behind the glass, a gray matte screen should be placed, 50 cm from the glass to be assessed.

In the case of such an assessment, glass defects cannot be particularly marked. Defects that are not visible from 3 m are not assessed.

When assessing glass defects, the following zones are distinguished: the edge zone, 15 mm wide, and the main zone, as shown in the figure below.

Fig.37 Division of enameled glass by screen printing method for visual evaluation

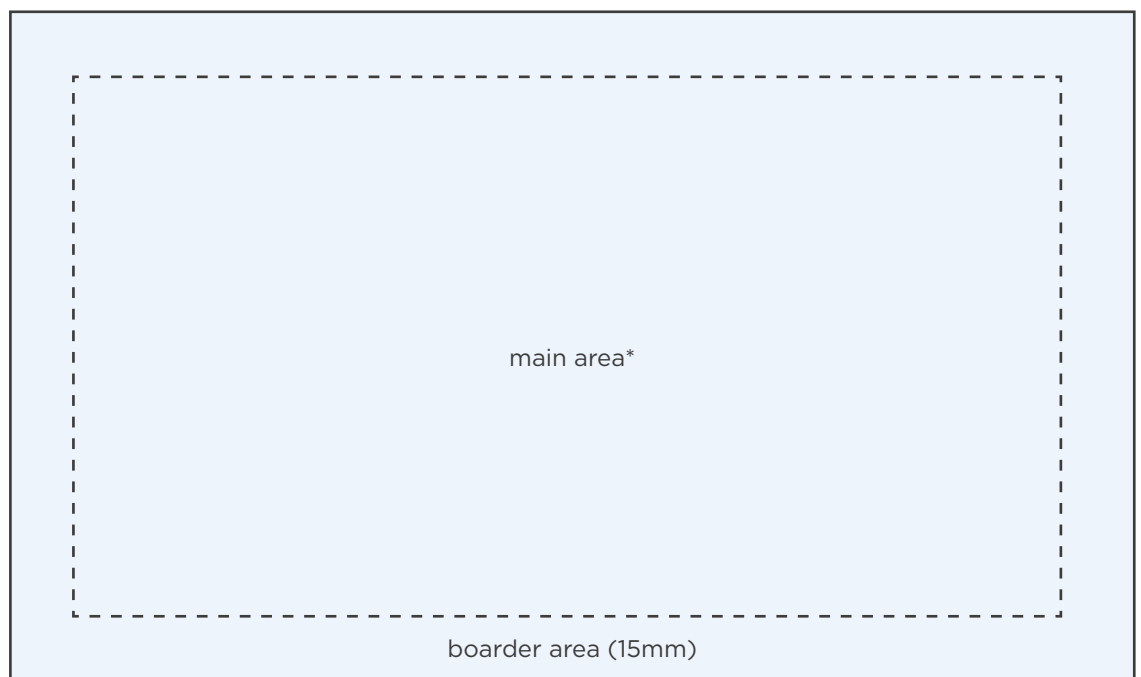

When the processing of painted glass is ordered (visible edges), the edge zone is omitted and the main zone extends to the edge of the glass.

The requirements for the visual assessment of enameled glass using the screen printing method are summarized in the form of a table - Tab. 37

Table 37

Type of defect	Main zone	Coastal zone
Point or line defects	A maximum of 3 defects within 25 mm ²	Width - max. 3 mm
Blackouts / fixes (patches)	Acceptable	Acceptable
Stains	Unacceptable	Acceptable
Printing outside the area and on the edges	Undesirable	Acceptable*
Dimensional tolerances of the print position. The print area: ≤ 100 mm ≤ 500 mm ≤ 1000 mm ≤ 2000 mm ≤ 3000 mm ≤ 4000 mm	Depends on the size of the print area: ± 1,0 mm ± 1,5 mm ± 2,0 mm ± 2,5 mm ± 3,0 mm ± 4,0 mm	-
Shape defects***	Print size: ≤ 200 cm: ± 2 mm Print size: > 200 cm: ± 4 mm	-
Tolerances of the position of the print area **		-
Pattern accuracy tolerance *** ≤ 30 mm ≤ 100 mm > 100 mm	Depends on the size of the print area: ± 0,8 mm ± 1,2 mm ± 2,0 mm	-

* Defects in the form of clearances with a diameter of ≤ 0.5 mm are acceptable and are generally not considered in the evaluation.

** Position tolerances are measured from the appropriate point.

*** The defect cannot be located closer than 250 mm from the other defects. Series defects are not permitted.

**** Tolerances can be added together.

A position defect is considered serial if it occurs on more than 3 panes. Position tolerances for partial printing are shown in Fig. 38.

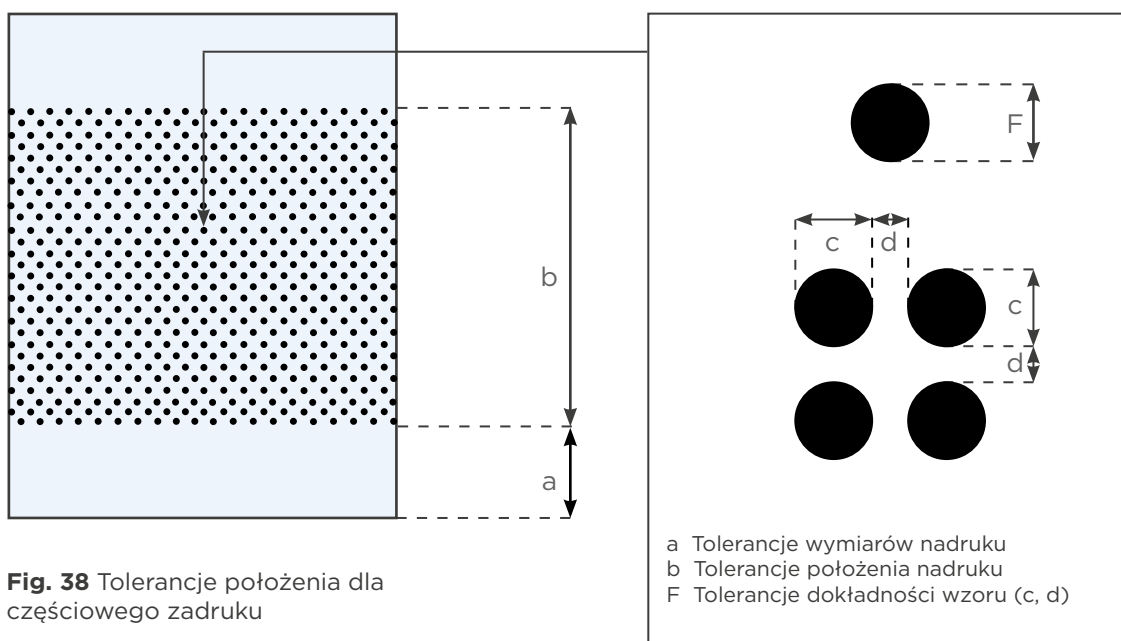

25.4 COLOR DIFFERENCE TOLERANCES

The assessment of the color differences of painted glass is made by comparing the shade of two products next to each other. Regarding the tolerances for color differences, the exact methods for assessing and classifying them have not been specified. This is because the human eye reacts differently to shade differences depending on the color it sees. Therefore, the assessment of the color shade of the imprint is a subjective assessment and may depend on various factors, including:

- batch of paint, batch of glass,
- heat treatment parameters,
- the use of coated glass,
- type of lighting, etc.

Below is a list of colors that can be processed at Glassolutions' production facilities:

RAL K7 CLASSIC				
Dostępane kolory / Available colours		* - not matched		M - metallic
		Cd - cadmium		
RAL1001	RAL5000	RAL6000	RAL7000	RAL8000
RAL1004 Cd/-	RAL5001 *	RAL6001	RAL7001	RAL8001
RAL1006	RAL5002	RAL6002 *	RAL7002	RAL8002
RAL1011	RAL5004	RAL6004	RAL7003	RAL8003
RAL1012 Cd/-	RAL5007	RAL6005	RAL7004	RAL8004
RAL1013 Cd/-	RAL5008	RAL6006	RAL7005	RAL8007
RAL1018 Cd/-	RAL5009	RAL6007	RAL7006	RAL8008
RAL1019	RAL5010	RAL6008	RAL7008	RAL8011
RAL1020 Cd/-	RAL5011	RAL6009	RAL7009	RAL8012
RAL1023 Cd/-	RAL5012	RAL6010	RAL7010	RAL8014
RAL1035 M	RAL5013	RAL6012	RAL7011	RAL8015
RAL1036 M	RAL5014	RAL6015	RAL7012	RAL8016
RAL2013 M	RAL5015	RAL6016	RAL7013	RAL8017
RAL3009	RAL5017 *	RAL6017 *	RAL7015	RAL8019
RAL3012	RAL5018	RAL6018	RAL7016	RAL8022
*RAL3033 M	RAL5019	RAL6020	RAL7021	RAL8024
	RAL5020	RAL6021	RAL7022	RAL8025
	RAL5021	RAL6022	RAL7023	RAL8028
	RAL5022	RAL6024	RAL7024	RAL8029
	RAL5023	RAL6026	RAL7026	RAL9001 Cd/-
	RAL5024	RAL6027	RAL7030	RAL9002
	RAL5025 M	RAL6028	RAL7031	RAL9003
	*RAL5026 M	RAL6029	RAL7032	RAL9004
		RAL6032	RAL7033	RAL9005
		RAL6033	RAL7034	RAL9006 M
		RAL6034	RAL7035	RAL9007 M
		RAL6035 M	RAL7036	RAL9010
		*RAL6036 M	RAL7037	RAL9011
			RAL7038	RAL9016
			RAL7039	RAL9017
			RAL7040	RAL9018
			RAL7042	RAL9022 M
			RAL7043	RAL9023 M
			RAL7044	
			RAL7045	
			RAL7046	
			RAL7047	
			RAL7048 M	

Table 38

Colors marked „Cd” contain cadmium, which is harmful to health and is prohibited for use in Saint-Gobain.

The colors marked with a red asterisk „*” contain a harmful substance and are prohibited for use in Saint-Gobain

25.5

STANDARD SCREEN PATTERNS

Fig. 39 Standard sieve patterns used by Glassolutions plants are as follows:

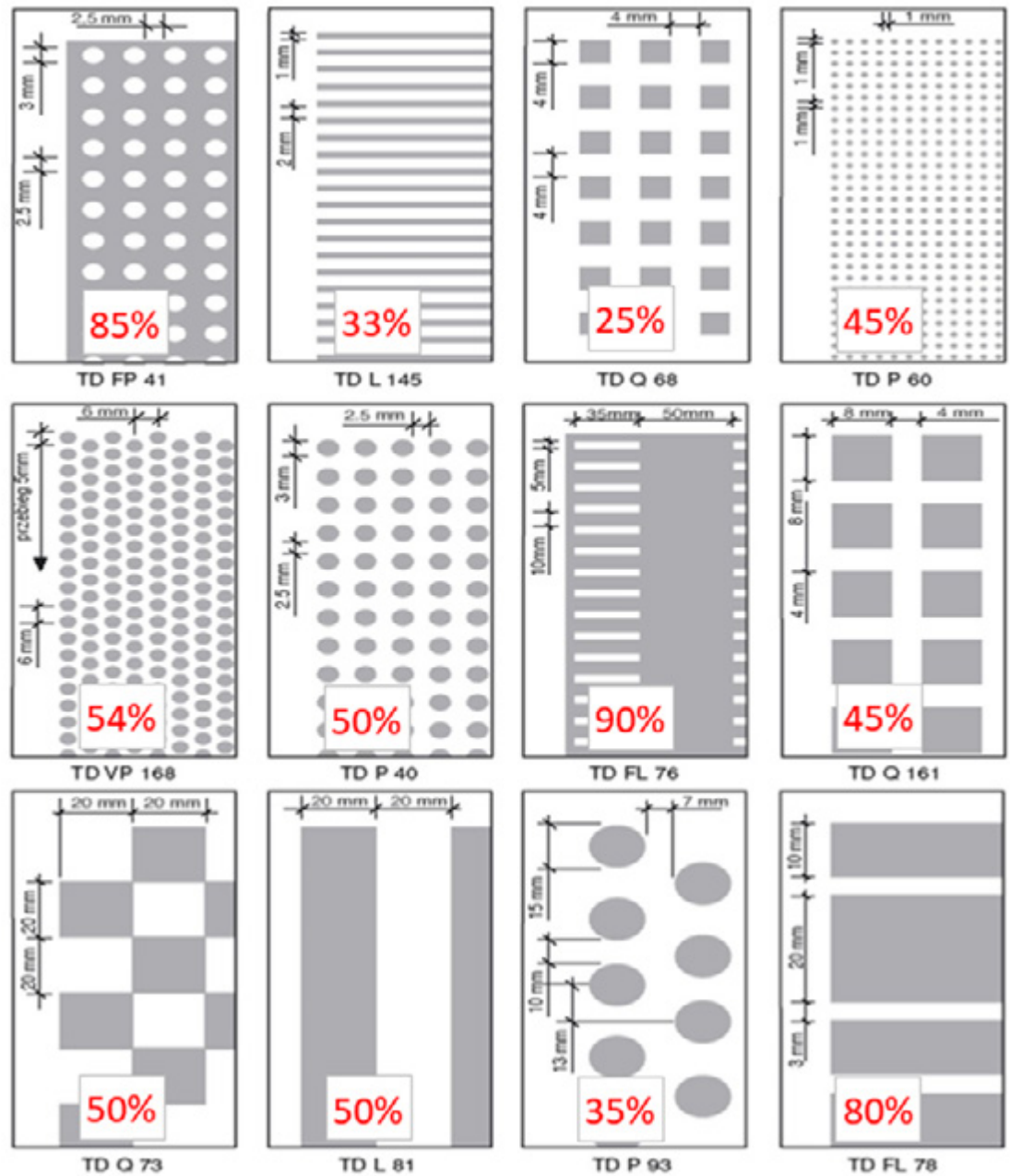

The above percentages marked in red indicate the coverage of the print on a given type of screen.



25.6

NON-SLIP COATING - SERALIT XTRAGRIP

Non-slip coatings used in the production of glass floors are also applied by screen printing. Glass floors are laminated glass, which usually consists of three layers, the bottom two of which are not tempered or heat strengthened glass (TVG), the outer layer is toughened glass with an anti-slip coating.

If it is necessary to test the anti-slip class of the floor, this service should be additionally ordered. The anti-slip class is guaranteed only at the time of order delivery, as the anti-slip layer is subject to change in parameters during use. The XtraGrip coating specifications are as follows.

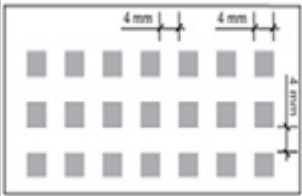
Table 39

Seralit XtraGrip (non-slip print for outdoor use) - R 11																																											
Paint	Special „side one” paint																																										
Colors	<p>Standard - imitation sandblasting Special (on request - see the list below)</p> <table border="1"> <tr> <td>RAL 1013</td> <td>RAL 3009</td> <td>RAL 5007</td> <td>RAL 7004</td> <td>RAL 7037</td> <td>RAL 8000</td> <td>RAL 9001</td> </tr> <tr> <td></td> <td>RAL 3013</td> <td>RAL 5015</td> <td>RAL 7005</td> <td>RAL 7040</td> <td></td> <td>RAL 9002</td> </tr> <tr> <td></td> <td></td> <td>RAL 5023</td> <td>RAL 7030</td> <td>RAL 7042</td> <td></td> <td>RAL 9003</td> </tr> <tr> <td></td> <td></td> <td>RAL 5024</td> <td>RAL 7032</td> <td>RAL 7044</td> <td></td> <td>RAL 9010</td> </tr> <tr> <td></td> <td></td> <td></td> <td>RAL 7035</td> <td>RAL 7045</td> <td></td> <td>RAL 9016</td> </tr> <tr> <td></td> <td></td> <td></td> <td></td> <td>RAL 7047</td> <td></td> <td>RAL 9018</td> </tr> </table>	RAL 1013	RAL 3009	RAL 5007	RAL 7004	RAL 7037	RAL 8000	RAL 9001		RAL 3013	RAL 5015	RAL 7005	RAL 7040		RAL 9002			RAL 5023	RAL 7030	RAL 7042		RAL 9003			RAL 5024	RAL 7032	RAL 7044		RAL 9010				RAL 7035	RAL 7045		RAL 9016					RAL 7047		RAL 9018
RAL 1013	RAL 3009	RAL 5007	RAL 7004	RAL 7037	RAL 8000	RAL 9001																																					
	RAL 3013	RAL 5015	RAL 7005	RAL 7040		RAL 9002																																					
		RAL 5023	RAL 7030	RAL 7042		RAL 9003																																					
		RAL 5024	RAL 7032	RAL 7044		RAL 9010																																					
			RAL 7035	RAL 7045		RAL 9016																																					
				RAL 7047		RAL 9018																																					
Patterns	<p>pełny zadruk</p>  <p>wzór TDQ 68 (kwadraty 4mmx4mm)</p>  <p>wzór SL-L03 (pasy 10mm co 10mm)</p> 																																										
Sieves	Specially dedicated to this product (difference in mesh capacity)																																										

A slippery floor can impact the safety of people walking across it. Understanding how slippery a floor is, is an important requirement.

The slip index, represented by the „R” value, refers to the method defined by the German standards DIN 51130 and 51097, which classify products based on their friction coefficient in response to the specific requirements of a given environment.

Depending on the degree of slipperiness, which may be associated with the use of certain substances at workplaces or the presence of water, these regulations require the use of a flooring material that generates significant friction between the contact surfaces and therefore causes the floor to be more secure. The higher the friction coefficient, the less slippery the floor becomes.

The standards distinguish between slippery floor surfaces in places where people walk in shoes (R9 - R13) and bare feet (A, B, C).

The measuring method specified in DIN 51130 distinguishes between the following slipperiness classes and provides guidance as to where they can be used:

- **R9** - entrances and staircases accessible from the outside; restaurants and canteens; shops; clinics; hospitals; schools.
- **R10** - shared toilets and showers; small kitchens in restaurants and cafes; garages and basements.
- **R11** - food production plants; medium-sized kitchens in restaurants and cafes; working environments with a lot of water and sludge; laboratories; laundries; hangars.
- **R12** - equipment for the production of food rich in fat, such as dairy products, cooking oils, sausages; large kitchens in restaurants and cafes; industrial areas where lubricants are used; parking lots.

- **R13** - places where large amounts of fat are used; food processing areas

Table 40 DIN 51130 classifies the results as follows:

Classification	Slip angle	Risk of slipping
R9	6° - 10°	High
R10	10° - 19°	High and moderate
R11	19° - 27°	Moderate and low
R12	27° - 35°	Low
R13	>35°	Low

25.7

ALARM LOOP

SECURIT ALARM is a glass reinforced by heat treatment (toughened), with a metal perimeter embedded in screen printing, usually placed in one of the corners, connected to the power supply and to the alarm. In case of glass breakage, the electric circuit is broken and an alarm is triggered. The diagram is shown in the figure below.

Fig. 40

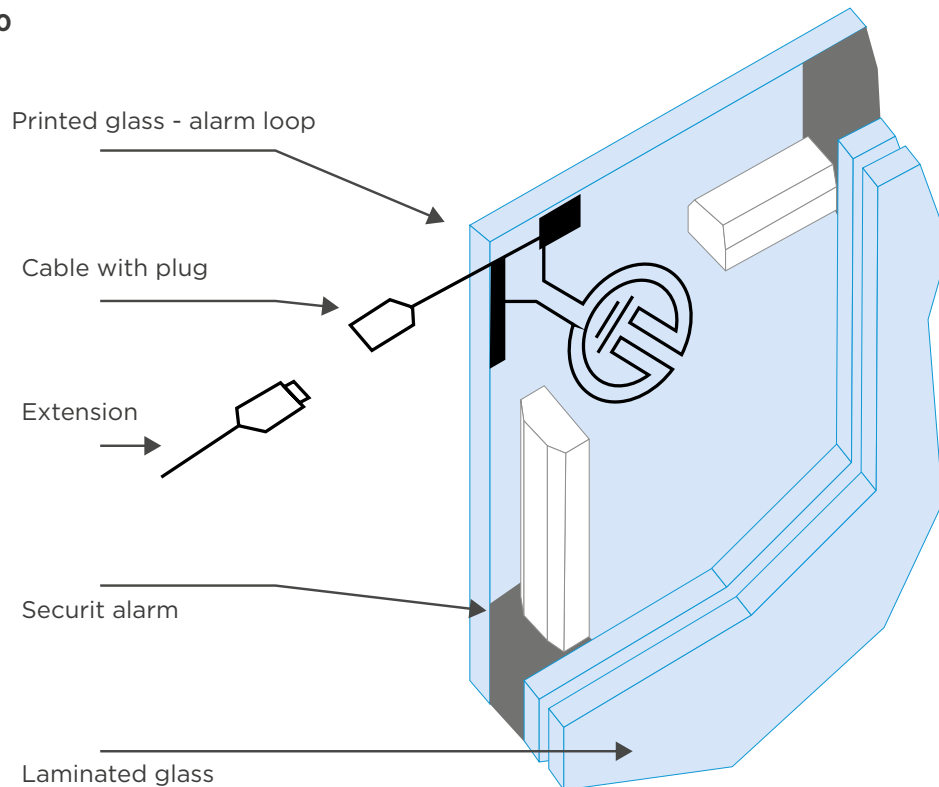

SECURIT ALARM has an alarm device class C (professional) - this means that it can even be used to secure such facilities as defense industry plants, metal and precious stones processing plants, valuable sacred buildings and their vaults, jewelry stores, museums, archives, banks. Details of the parameters of glass panes with an alarm loop are presented in the table:

Table 41 Details of glass parameters SECURIT ALARM

Windshields with an alarm loop SECURIT ALARM	
Basic parameters	Loop resistance: 1 – 6 Ω ; Current: \leq 100 mA
Type of glass	Coating free / Antelio and softcoated
Location of the loop	<ul style="list-style-type: none"> At the corner specified by the customer Possible anywhere near the edge
Solution	It is possible to applications an alarm loop on single, laminated and composite glass DGU and TGU
Remarks	<ul style="list-style-type: none"> The SECURIT ALARM product is accompanied by a document - „Product specification” On the tin side of the glass the loop has a different color than on the air side - it is recommended to print on the air side of the glass A 33 cm long wire is permanently soldered to each type of glass with an alarm loop (it is recommended to order cable extensions 1.5 m, 5 m, 10 m long)

* hard and soft-coated glass requires additional grinding of the coating - contact the Technical Department

Fig. 41

Additionally, there are 3 different positions of the applied loop, depending on the glass design

1. Forma wykonania SGG SECURIT* ALARM – przyłącze narożne ASR typ V

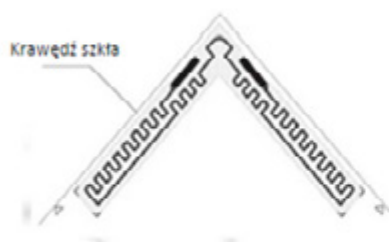

Rysunek 1

- Pozycja narożna
- Dla połączenia z izolacyjnym szkłem zespolonym i laminowanym
- Minimalna grubość szkła to 6mm
- Szkło miękkopowłokowe i pozostałe
- Minimalny szlif powłoki 12mm

2. Forma wykonania SGG SECURIT* ALARM – przyłącze narożne ASR typ VD

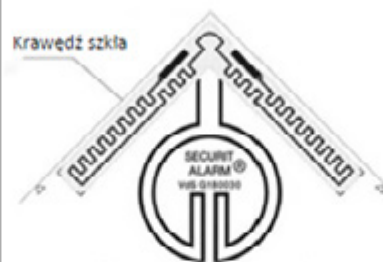

Rysunek 2

- Pozycja narożna
- Dla połączenia z izolacyjnym szkłem zespolonym i laminowanym
- Minimalna grubość szkła to 6mm
- Szkło pozostałe [poza miękka powłoką]
- Minimalny szlif powłoki 12mm

3. Forma wykonania SGG SECURIT* ALARM – przyłącze krawędziowe modelowe ASR typ VD



Rysunek 3

- Pozycja krawędziowa (prostokąty i modele)
- Dla połączenia z izolacyjnym szkłem zespolonym i laminowanym
- Stosowana w modelach nie owalnych i z kątem minimalnym 60°
- Minimalna grubość szkła to 6mm
- Szkło miękkopowłokowe i pozostałe
- Minimalny szlif powłoki 12mm

Structural glazing

Silicone structural glazing is a method that uses a silicone adhesive to bond glass, metal, or other panel materials to the structural elements of a building. The wind pressure on the facade is transferred to the structural elements of the building by means of the sealant. The sealant must maintain its adhesion and cohesiveness to support the weight of the panels connected to the facade. Structural glazing (SG) is a high performance application and not all silicones are suitable for this application.

Only silicone sealants specifically developed and tested for structural glazing may be used. DOW® Structural Glazing products are covered in detail in the following sections of this guide. Each DOW structural glazing silicone has been granted a „European Technical Approval” (ETA) after independent testing in accordance with current European structural glazing standards: European Technical Approval Guidelines (ETAG 002). These silicones are CE marked, which means compliance with European legal regulations concerning health, safety and environmental protection.

26.1

PRODUCTS USED BY GLASSOLUTIONS

- DOW® 993 Structural Glazing Silicone Sealant DOW 993 Structural Glazing Silicone Sealant is a two component, fast curing, neutral curing silicone for structural bonding applications to glass, metal and other panels. Compared to conventional one-component silicones, the fast-setting properties of DOW 993 silicone allow for more efficient production of structurally glazed curtain walls. DOW 993 is a high modulus sealant with excellent adhesion to a wide range of building materials. DOW 993 obtained the „European Technical Approval” (ETA) based on independent tests carried out in accordance with the current European guidelines for structural glazing ETAG 002. Based on this approval, this silicone has obtained the CE mark of conformity.
- DOW® 3363 Insulating Glass Silicone Sealant is a two-component, fast-setting, neutral curing sealant used as a secondary seal in the production of insulated glass units.
- DOW® R-40 Cleaner DOW R-40 Cleaner The cleaner is a solvent specially designed for cleaning glass and metal profiles used in structural glazing.
- DOW® 1203 OS Primer DOW 1200 OS Primer is a primer supplied as a solution for a variety of applications together with DOW sealants.

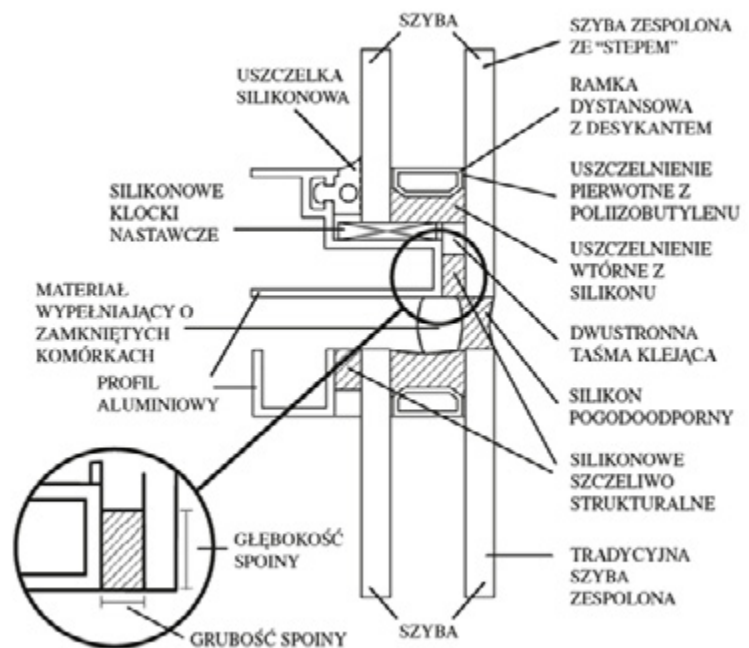

Fig. 42 Elements of a typical structural glazing

26.2

TYPES OF STRUCTURAL GLAZING SYSTEMS

There are many different structural glazing systems. A common feature of all these systems is the use of structural silicone to structurally join glass or other material to the building structure. The most common types of systems are described below:

Four-sided structural glazing

4-sided structural glazing is the most common and usually the most cost-effective type of structural glazing in European countries. The glass is supported by structural silicone on all four sides of the glass. Quadruple structural glazing systems are typically fabricated in a factory and assembled on site.

Double-sided structural glazing

Double-sided structural glazing is a system in which structural silicone is located on two of the four sides of the glass. The other two sides of the glass are mechanically fastened or are not structurally glued to the frame. The double-sided structural glazing system is manufactured in a factory or on a construction site.

Inclined glazing

Sloped glazing is a system where structural glazing is used on a sloped facade. Skylights are a typical example of this type of structural glazing. In such cases, the weight of the glass should be considered when calculating the dimensions of the structural joint. For inclined glazing, European legislation requires the use of laminated safety glass.

Glass „with a step”

In many structural glazing systems, the structural joint runs along the inner surface of the outer pane. In this system, IG units are manufactured with a step, which allows gluing to the outer pane. In more traditional structural glazing systems, the structural joint runs across the inner surface of the inner glazing of the assembly. An example of a typical stepped glass pane in a structural glazing system is shown in Figure 2.1.

Glazing systems with a U profile

There are many systems that make it possible to mechanically connect the IG unit to the structure using a U-shaped profile in the cavity between the two panes. Depending on the system, silicone sealant can be used as a structural, structural or insulating sealant in a design. Any such system must be approved by the DOW Technical Service.

Translucent fin systems

Vision systems, commonly used on the front wall of a building to increase the vision area, use glass fins to structurally support vision glass. In such cases, double-sided structural glazing systems can use structural silicone between the edge of the glass and the glass fin. DOW allows the weld to work in shear if it is independent of the shear work of the weld.

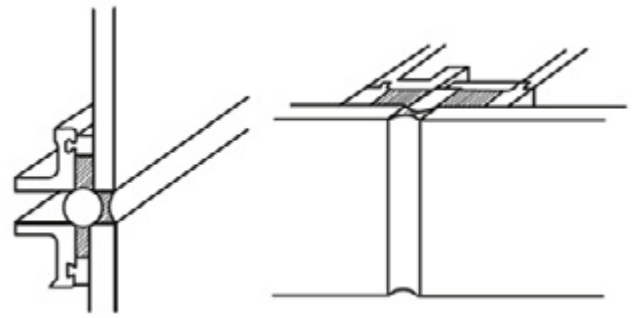
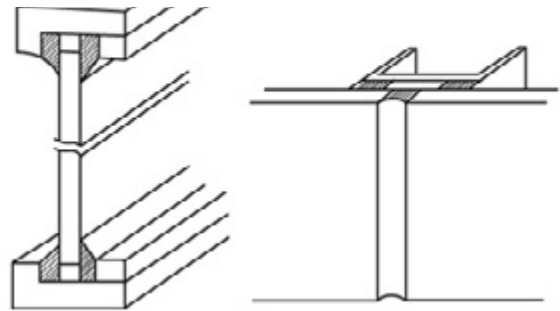

Fig. 43



26.3**SEALING WITH SILICONE - DOUBLE GLAZING****Table 42**

Szyby uszczelnione silikonem (odporność na promieniowanie UV)								
Kind of outer sealant	Type of filling the space between the panes	Frame		Gas filling	Desiccant filling	Comments		
		Material	Type of processing					
DOW 3362 / DOW 3363	AIR	Aluminium	Cut or bent	-	Min. 2 sizes			
		Steel						
		Swisspacer V	Cut		4 sizes			
		Chromatech Ultra						
	ARGON	Aluminium	Cut or bent		Automatically or manually*		Min. 2 sizes	The connection of cut frames protected
		Steel						
		Swisspacer V	Cut				4 sizes	
		Swisspacer Ultimate						
		Chromatech Ultra	Cut or bent					
	KRYPTON	Aluminium	Cut or bent	Automatically or manually*	Min. 2 sizes	The connection of cut frames protected		
		Stal						
		Swisspacer V	Cut		4 sizes			
		Swisspacer Ultimate						
		Chromatech Ultra	Cut or bent					

* Manual gassing requires one side to be left without the molecular sieve in order to insert the nozzle gas engineers

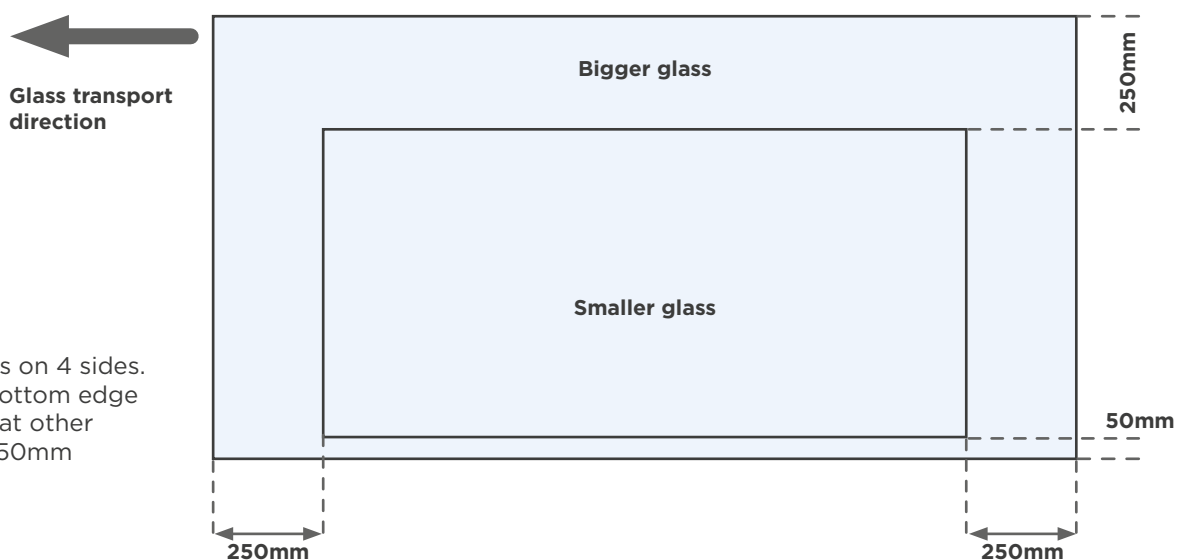
26.4**STEPPED GLASS****Rys. 44**

Stepped glass on 4 sides. Step at the bottom edge max 50 mm, at other edges max 250mm

26.5**QUALITY CONTROL OF SEALANTS**

Quality control is one of the most important components of a successful structural glazing project and is one of the main responsibilities of the contractor.

During production, periodic quality control of the DOW Structural Silicone Sealant applied using the Two-Component Mass Proportioner should be performed.

The test procedures are to verify that the sealant has been properly mixed in the correct ratio. These tests and the recommended frequency of their performance are presented in the table below.

Table 43

Quality control of mixing sealants	Frequency of tests		
	Each time the pump is turned on	After each drum replacement	Technical support of the device
Test on glass	Required*	Required*	Required
Butterfly test	Required*	Wymagany*	Required
Snap time test	Required	Required	Required
Mixing ratio	Not required	Not required	Not required

* Either glass test or butterfly test required.

27**Final Provisions**

Other phenomena occurring in different types of glasses, special features, physical and mechanical properties, tolerances, requirements, methods of testing and descriptions not included in this study are the subject of European standards appropriate for each product.

European standards are available for inspection at the manufacturer's premises.

Additional requirements for cooperation with Glassolutions Polska are described in the „General Conditions of Sale” available on the website: www.glassolutions.pl and remain valid.

Additional requirements for some products are related to individual national markets (French, Scandinavian, Danish, etc.).



Saint-Gobain Sp. z o.o.
GLASSOLUTIONS

32-310 Jaroszewiec,
ul. Kolejowa 1

www.glassolutions.pl